

**SAMSUNG**

**HC-P4252W  
HC-P4752W  
HC-P5252W**

**PROJECTION TELEVISION**

**SAMSUNG**

**ELECTRONICS**

**1-800-SAMSUNG (1-800-726-7864)**

**Samsung Electronics America  
Service Division**

400 Valley Road, Suite 201  
Mount Arlington, NJ 07856  
[www.samsungusa.com](http://www.samsungusa.com)

**Samsung Electronics Canada Inc.  
Samsung Customer Care**

7037 Financial Drive  
Mississauga, Ontario  
L5N 6R3  
[www.samsung.ca](http://www.samsung.ca)

**Owner's  
Instructions**

## Important Warranty Information Regarding Television Format Viewing

Standard screen format televisions (4:3, the aspect ratio of the screen width to height) are primarily designed to view standard format full-motion video. The images displayed on them should primarily be in the standard 4:3 ratio format and constantly moving. Displaying stationary graphics and images on screen, such as the dark top and bottom letterbox bars (wide screen pictures), should be limited to no more than 15% of the total television viewing per week.

Wide screen format televisions (16:9, the aspect ratio of the screen width to height) are primarily designed to view wide screen format full-motion video. The images displayed on them should primarily be in the wide screen 16:9 ratio format, or expanded to fill the screen if your model offers this feature, and constantly moving. Displaying stationary graphics and images on screen, such as the dark side-bars on non-expanded standard format television video and programming, should be limited to no more than 15% of the total television viewing per week.

Additionally, viewing other stationary images and text such as stock market reports, video game displays, station logos, web sites or computer graphics and patterns, should be limited as described above for all televisions. ***Displaying any stationary images that exceed the above guidelines can cause uneven aging of picture tubes (CRTs) that leave subtle, but permanent burned-in ghost images in the television picture. To avoid this, vary the programming and images, and primarily display full screen moving images, not stationary patterns or dark bars.*** On television models that offer picture sizing features, use these controls to view the different formats as a full screen picture.

Be careful in the selection and duration of television formats used for viewing. Uneven CRT aging as a result of format selection and use, as well as other burned-in images, is not covered by your Samsung limited warranty.

<b>Chapter 1: Your New TV .....</b>	<b>5</b>
List of Features .....	5
Accessories .....	5
Familiarizing Yourself with Your New TV .....	6
Control Buttons .....	6
Connection Jacks (Side or Front) .....	7
Connection Jacks (Rear) .....	8
Remote Control .....	9
<b>Chapter 2: Installation .....</b>	<b>10</b>
Connecting VHF and UHF Antennas .....	10
Antennas with 300-ohm Flat Twin Leads .....	10
Antennas with 75-ohm Round Leads .....	11
Separate VHF and UHF Antennas .....	11
Connecting Cable TV .....	12
Cable without a Cable Box .....	12
Cable with a Cable Box that Descrambles All Channels .....	12
Connecting to a Cable Box that Descrambles some Channels .....	13
Connecting a VCR .....	14
Connecting a Second VCR to Record from the TV .....	14
Connecting a DVD Player .....	15
Connecting to Y, P <sub>B</sub> , P <sub>R</sub> .....	15
Connecting to Regular Audio and Video Jacks .....	15
Connecting a Digital TV Set-Top Box .....	16
Connecting to Y, P <sub>B</sub> , P <sub>R</sub> .....	16
Connecting to DVI (Digital Visual Interface) .....	17
Connecting to HDMI (High Definition Multimedia Interface) .....	17
Connecting a Camcorder .....	18
Installing Batteries in the Remote Control .....	19
<b>Chapter 3: Operation .....</b>	<b>20</b>
Turning the TV On and Off .....	20
Plug & Play Feature .....	20
Viewing the Menus and On-Screen Displays .....	22
Viewing the Menus .....	22
Viewing the Display .....	22
Selecting a Menu Language .....	23
Selecting the Antenna Input .....	23
Adjusting the Screen Automatically (Self Focus) .....	24
Deactivating the Automatic Execution of the Self Focus .....	25
Removing the “Self Focus” Message from the Display .....	25
Memorizing the Channels .....	26
Selecting the Video Signal Source .....	26
Storing Channels in Memory (Automatic Method) .....	27
Adding and Erasing Channels .....	28
Changing Channels .....	29
Using the Channel Buttons .....	29
Using the Number Buttons .....	29
Using the Previous Channel .....	29
Selecting Your Favorite Channels .....	30
To Store Your Favorite Channels .....	30
To View Your Favorite Channels .....	30
Labeling the Channels .....	31
Picture Control .....	32
Customizing the Picture .....	32
Using Automatic Picture Settings .....	33

<b>Chapter 3: Operation</b> (continued) .....	<b>34</b>
Sound Control.....	34
Adjusting the Volume .....	34
Using the MUTE Button .....	34
Customizing the Sound .....	34
Using Automatic Sound Settings .....	35
Setting the Clock.....	36
Option 1: Setting the Clock Manually .....	36
Option 2: Setting the Clock Automatically .....	37
Viewing an External Signal Source .....	39
Setting the Signal Source .....	39
Assigning Names to External sources .....	40
<b>Chapter 4: Special Features</b> .....	<b>41</b>
Fine Tuning Channels .....	41
Scanning the Channels .....	42
Selecting the Color Tone .....	43
Changing the Picture Size .....	44
Digital Noise Reduction .....	45
Viewing Picture-In-Picture .....	46
Activating the PIP.....	46
Selecting an External Source .....	47
Swapping the Sub picture and Main picture .....	47
Changing the Size of the Sub picture .....	47
Changing the Location of the Sub picture .....	48
Selecting a Signal Source for the Sub picture .....	48
Changing the Channel of the Sub picture .....	49
Freezing the Picture .....	49
Choosing a Multi-Channel Sound (MTS) track .....	50
Auto Volume .....	51
Setting the SRS TSXT .....	52
Setting the On/Off Timer.....	53
Setting the Sleep Timer .....	54
Setting the Blue Screen Mode .....	55
Viewing Closed Caption Information .....	56
Setting the On/Off Melody .....	57
Selecting the HDMI Standard .....	58
Using the V-Chip.....	59
How to Change Your Password .....	59
How to Enable/Disable the Rating Controls .....	60
How to Set up Restrictions Using the “TV Parental Guidelines” .....	61
How to Set up Restrictions Using the “MPAA Rating” .....	62
Important Notes About Parental Locks.....	63
How to Set up Restrictions Using the “Canadian English” .....	64
How to Set up Restrictions Using the “Canadian French” .....	65
Customizing Your Remote Control .....	66
Setting Up Your Remote Control to Operate Your VCR (Cable box or DVD player).....	66
Remote Control Codes .....	67
<b>Chapter 5: Troubleshooting</b> .....	<b>68</b>
Identifying Problems .....	68
<b>Appendix</b> .....	<b>69</b>
Cleaning and Maintaining Your TV .....	69
Using Your TV in Another Country.....	69
Specifications .....	69

# Chapter One

## YOUR NEW TV

### List of Features

Your TV was designed with the latest technology. This TV is a high-performance unit that includes the following special features:

- Easy-to-use remote control
- Easy-to-use on-screen menu system
- Automatic timer to turn the TV on and off
- Adjustable picture and sound settings that can be stored in the TV's memory
- Automatic channel tuning for up to 181 channels
- A special filter to reduce or eliminate reception problems
- Fine tuning control for the sharpest picture possible
- A built-in multi-channel sound decoder for stereo and bilingual listening
- Built-in, dual channel speakers
- A special sleep timer
- **Picture-In-Picture** capability that lets you watch two channels at once
- Component Video Input jacks to obtain a sharper image from external sources
- Adjusting the Screen Automatically (Self Focus)
- Digital Inputs
  - DVI - Digital Visual Interface
  - HDMI - High Definition Multimedia Interface

### Accessories

Once you have unpacked your TV, check to make sure that you have all the parts shown here. If any piece is missing or broken, call your dealer.

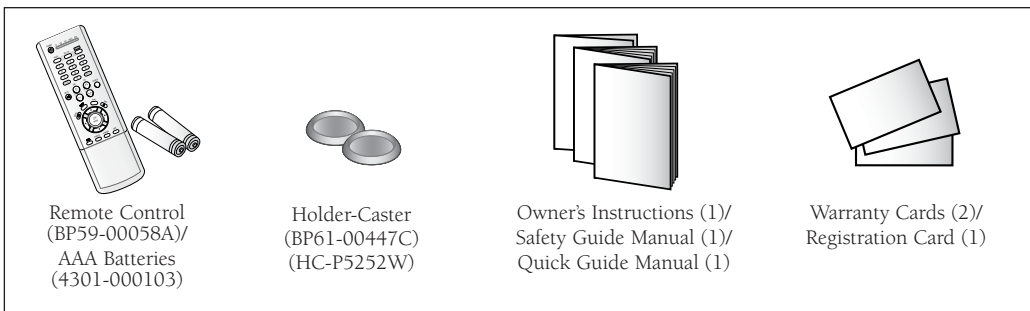

## Familiarizing Yourself with Your New TV

### Control Buttons

You can control your TV's basic features, including the on-screen menu. To use the more advanced features, you must use the remote control.

- The actual configuration on your TV may be different, depending on your model.

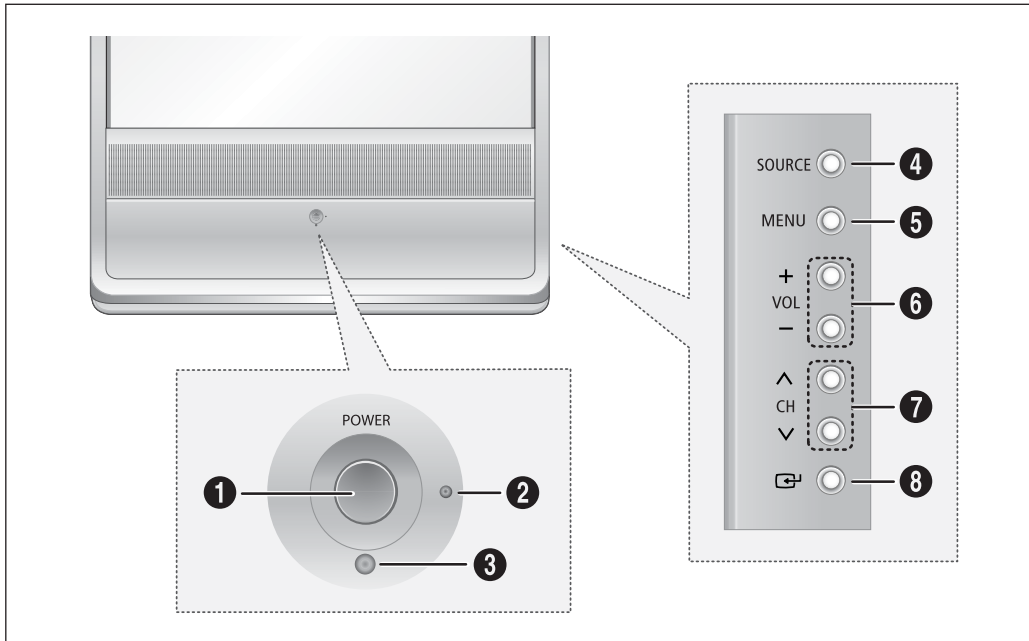

#### 1 POWER

Press to turn the TV on and off.

#### 2 Stand-By Indicator

Lights up when you turn the power off.

- Power Off ; Red
- Power On ; Off
- Timer On ; Green

#### 3 Remote Control Sensor

Aim the remote control towards this spot on the TV.

#### 4 SOURCE

Press to switch between viewing TV programs and signals from connected components.

#### 5 MENU

Press to see an on-screen menu of your TV's features.

#### 6 + VOL -

Press to lower or raise the volume and to select items when using the on-screen menu.

#### 7 ^ CH v

Press to change channels and move between items on the on-screen menu.

#### 8 (Enter)

While using the on-screen menus, press to activate (or change) a particular item.

### Connection Jacks (Side or Front)

You can connect an A/V component that is used only occasionally, such as a camcorder or video game. For information on connecting equipment, see page 18.

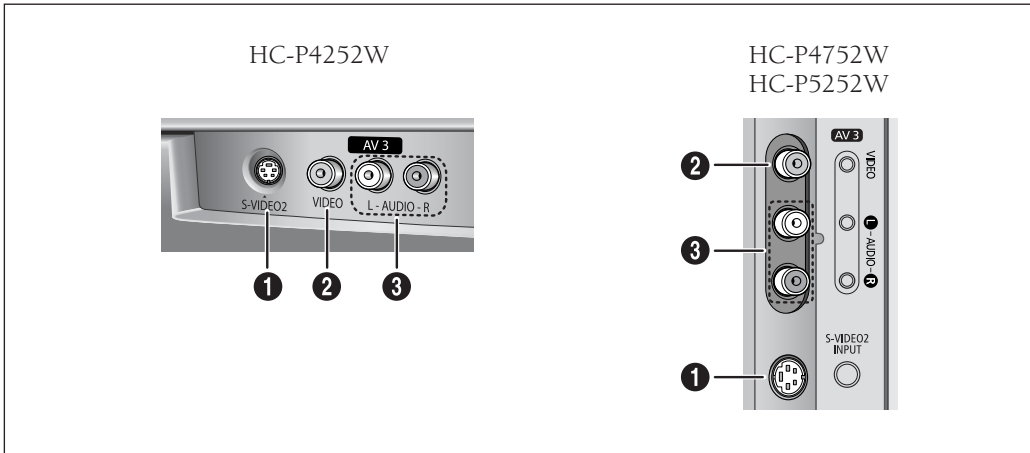

- 1 S-VIDEO Input**  
Connect an S-Video signal from a camcorder or video game.
- 2 VIDEO Input**  
Connect the video signal from a camcorder or video game.
- 3 AUDIO Input**  
Connect the audio signals from a camcorder or video game.

## Connection Jacks (Rear)

Use the rear panel jacks to connect an A/V component that will be connected continuously, such as a VCR or a DVD player. For more information on connecting equipment, see pages 10~17.

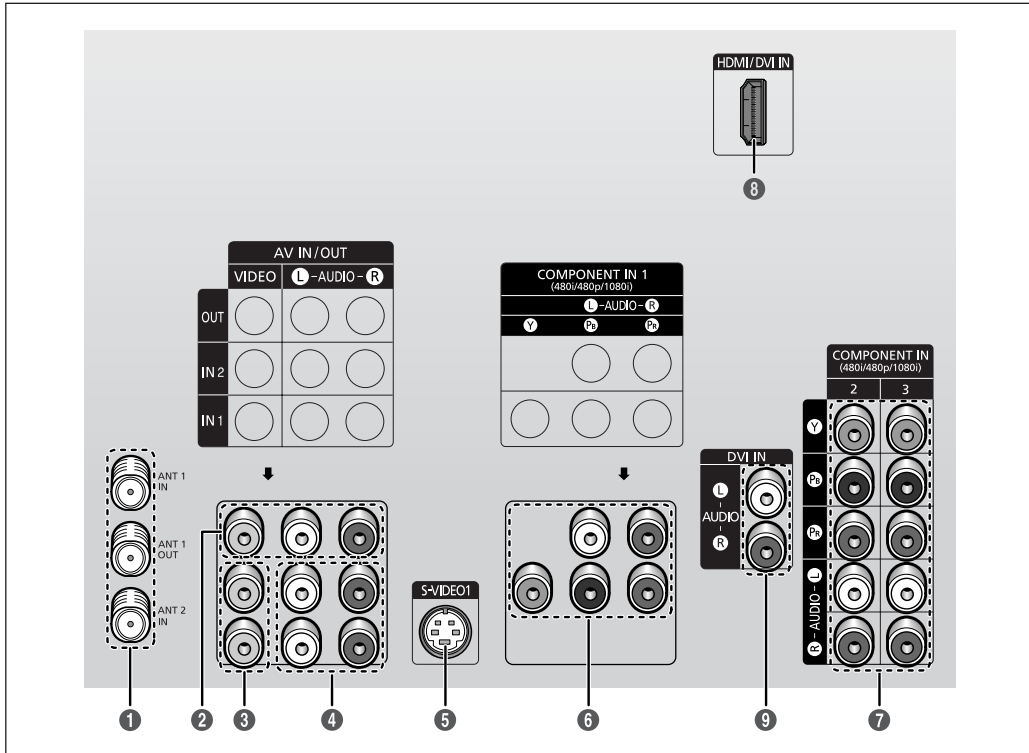

### 1 Antenna terminals

Two independent cables or antennas can be connected to these terminals. Use "ANT 1 IN" and "ANT 2 IN" terminals to receive a signal from VHF/UHF antennas or your cable system. Use the "ANT 1 OUT" terminal to send the signal being received by the "ANT 1 IN" terminal out to another component (such as a Cable Set-Top Box). The PIP channel can be received only when a signal source is connected to "ANT 1 IN".

### 2 Audio/Video Output jacks

Connect to the audio/video input jacks of a recording VCR.

### 3 Video Input jacks

Connect to the video output jacks of VCRs, DVD players and similar devices.

### 4 Audio Input jacks

Connect to the audio output jacks of VCRs, DVD players and similar devices.

### 5 S-Video Input jack

Connect to S-VIDEO output jacks of an S-VHS VCR or DVD player.

### 6 7 COMPONENT Input jacks (Y, PB, PR, AUDIO-L/R)

Connect to the audio and video outputs of DVD or DTV Set-Top Box. 480i/480p/1080i Y, PB and PR video signal outputs are available.

### 8 HDMI/DVI Video Input jack

(High Definition Multimedia Interface)

Connect to the HDMI jack for device with HDMI or DVI output.

### 9 DVI Audio Input jacks

(Digital Visual Interface)

Connect to the digital audio output jacks for device with DVI output.



## Remote Control

You can use the remote control up to about 23 feet from the TV. When using the remote control, always point it directly at the TV. You can also use your remote control to operate your Set-Top box, VCR, Cable box or DVD player. See pages 64~65 for details.

### 1 POWER

Turns the TV on and off.

### 2 P.SIZE

Press to change the picture size.

### 3 FAV. CH (Favorite Channel)

Press to switch between your favorite channels.

### 4 Number buttons

Press to select channels directly on the TV.

### 5 +100

Press to select channels over 100. For example, to select channel 121, press the "+100," then press the "2" and "1."

### 6 MUTE

Press to temporarily cut off the sound.

### 7 VOL +, VOL -

Press to increase or decrease the volume.

### 8 SLEEP

Press to select a preset time interval for automatic shut off.

### 9 MENU

Displays the main on-screen menu.

### 10 STILL (Main picture)

Press to stop the action during a particular scene. Press again to resume normal video. The still function doesn't operate in "Component 1, 2, 3" mode.

### 11 P.MODE

Adjust the TV picture by selecting one of the preset factory settings (or select your personal, customized picture settings.)

### 12 SRS TSXT

Activates TruSurround.

### 13 ADD/DEL

Press to add or erase channels in the TV's memory. Use to memorize or erase the fine tuning after fine tuning channels.

### 14 CAPTION

Press to view closed caption information.

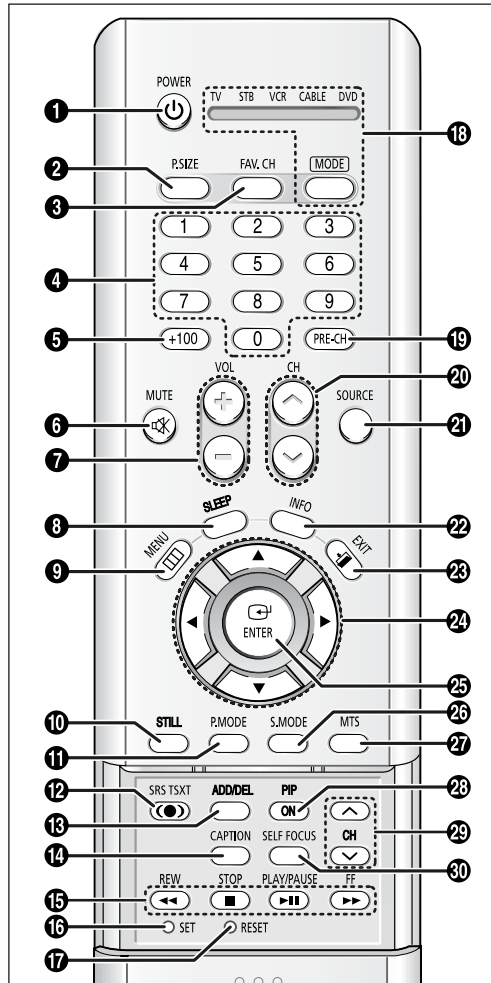

### 18 MODE

Selects a target device to be controlled by this remote control (i.e., TV, STB, VCR, CABLE or DVD).

### 19 PRE-CH

Tunes to the previous channel.

### 20 CH^, CHv

Press to change channels.

### 21 SOURCE

Each time the button is pressed, all the inputs connected to the external component jacks will be shown in regular sequence.

### 22 INFO

Press to display information on the TV screen.

### 23 EXIT

Press to exit the menu.

### 24 ◀/▶/▼/▲

Control the cursor in the menu.

### 25 ENTER

While using the on-screen menus, press ENTER to activate (or change) a particular item.

### 26 S.MODE

Adjust the TV sound by selecting one of the preset factory settings (or select your personal, customized sound settings.)

### 27 MTS (Multichannel Television Sound)

Press to choose "Stereo", "Mono" or "SAP (Secondary Audio Program)".

### 28 PIP ON

Activates PIP (Picture-In-Picture).

### 29 CH^, CHv

Displays the available channels in sequence. (These buttons change channels in the PIP window only.)

### 30 SELF FOCUS

Press to adjust for the optimum picture set in the factory.

### 15 VCR/DVD Controls

Controls VCR/DVD functions: Rewind, Stop, Play/Pause, Fast Forward.

### 16 SET

Used during set up of this remote control, so that it will work compatibly with other devices (VCR, Set-Top box, Cable box, DVD, etc.)

### 17 RESET

If your remote control is not functioning properly, take out the batteries and press the **RESET** button for about 2~3 seconds. Re-insert the batteries and try using the remote control again.

# Chapter Two

## INSTALLATION

### Connecting VHF and UHF Antennas

If your antenna has a set of leads that look like this, see “Antennas with 300-ohm Flat Twin Leads,” below.

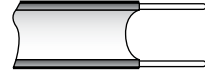

If your antenna has one lead that looks like this, see “Antennas with 75-ohm Round Leads,” on next page.



If you have two antennas, see “Separate VHF and UHF Antennas,” on next page.

### Antennas with 300-ohm Flat Twin Leads

If you are using an off-air antenna (such as a roof antenna or “rabbit ears”) that has 300-ohm twin flat leads, follow the directions below.

**1**

Place the wires from the twin leads under the screws on the 300-75 ohm adaptor (not supplied). Use a screwdriver to tighten the screws.

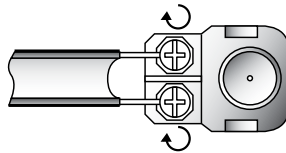

**2**

Plug the adaptor into the “ANT 1 IN” terminal on the rear panel.

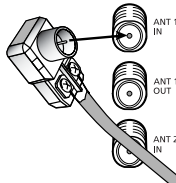

# INSTALLATION

## Antennas with 75-ohm Round Leads

Plug the antenna lead into the "ANT 1 IN" terminal on the rear panel.

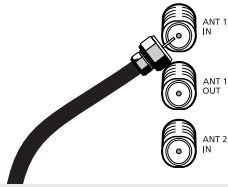

## Separate VHF and UHF Antennas

If you have two separate antennas for your TV (one VHF and one UHF), you must combine the two antenna signals before connecting the antennas to the TV. This procedure requires an optional combiner-adaptor (available at most electronics shops).

**1**

Connect both antenna leads to the combiner.

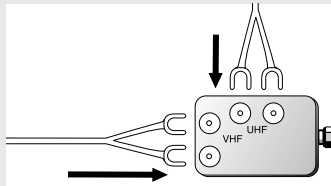

**2**

Plug the combiner into the "ANT 1 IN" terminal on the rear panel.

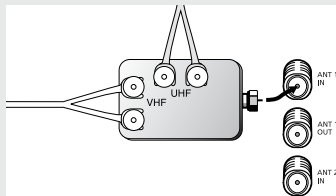

## Connecting Cable TV

You can connect different cable systems to your TV, including cable without a cable box, and cable with a cable box that descrambles some or all channels.

### Cable without a Cable Box

If you want to connect cable, and you do not need to use a cable box:

Plug the incoming cable into the "ANT 1 IN" terminal on the rear panel.

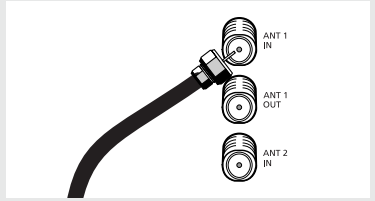

### Cable with a Cable box that Descrambles All Channels

**1**

Find the cable that is connected to the ANTENNA OUT terminal on your cable box.

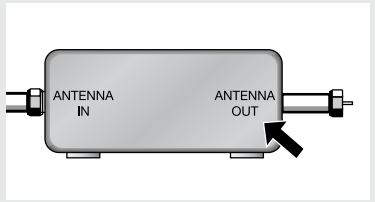

◀ This terminal might be labeled "ANT OUT", "VHF OUT", or simply "OUT".

**2**

Connect the other end of this cable to the "ANT 1 IN" terminal on the rear panel.

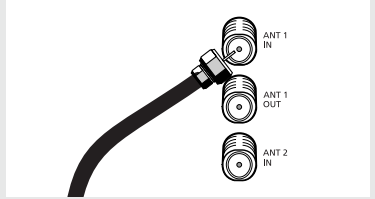

### Connecting to a Cable Box that Descrambles Some Channels

If your cable box descrambles only some channels (such as premium channels), follow the instructions below. You will need a two-way splitter, an RF (A/B) switch, and four lengths of coaxial cable. (These items are available at most electronics stores.)

- 1**  
Find and disconnect the cable that is connected to the ANTENNA IN terminal on your cable box.

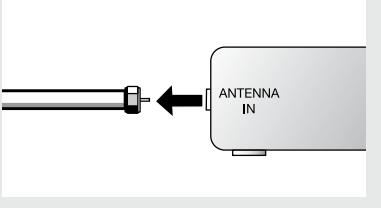

◀ This terminal might be labeled “ANT IN”, “VHF IN”, or simply “IN”.
- 2**  
Connect this cable to a two-way splitter. Connect a coaxial cable between an OUTPUT terminal on the splitter and the IN terminal on the cable box.

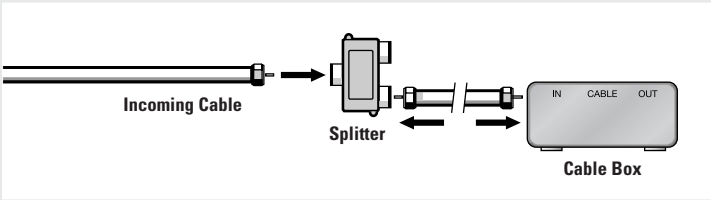
- 3**  
Connect a coaxial cable between the ANTENNA OUT terminal on the cable box and the B-IN terminal on the A/B switch.

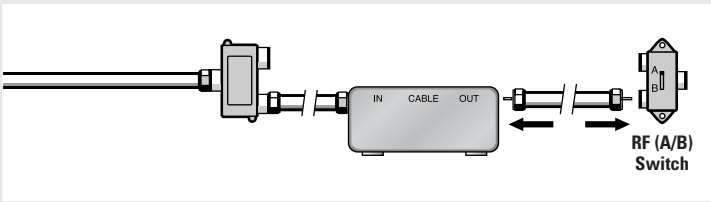
- 4**  
Connect another cable between the other OUT terminal on the splitter and the A-IN terminal on the RF (A/B) switch.

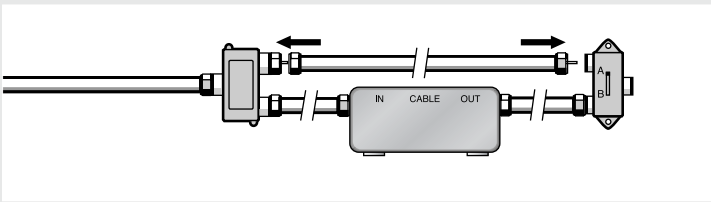
- 5**  
Connect the last coaxial cable between the OUT terminal on the RF (A/B) switch and the “ANT 1 IN” terminal on the rear panel.

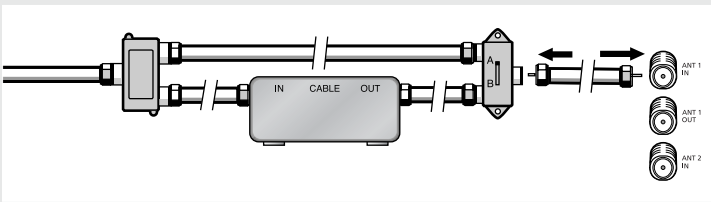

After you’ve made this connection, set the A/B switch to the “A” position for normal viewing. Set the A/B switch to the “B” position to view scrambled channels. (When you set the A/B switch to “B,” you will need to tune your TV to the cable box’s output channel, which is usually channel 3 or 4.)

## Connecting a VCR

These instructions assume that you have already connected your TV to an antenna or a cable TV system (according to the instructions on pages 10-13). Skip step **1** if you have not yet connected to an antenna or a cable system.

### 1

Connect a coaxial cable between the "ANT IN" (1 or 2) terminal on the TV and the ANTENNA OUT terminal on the VCR.

A coaxial cable is usually included with a VCR. (If not, check your local electronics store).

### 2

Connect a set of audio cables between the "AV IN 1 (L, R)" (or "AV IN 2 (L, R)") jacks on the TV and AUDIO OUT jacks on the VCR.

If you have a mono VCR, connect L(mono) to VCR audio out using only one audio cable.

### 3

Connect a video cable between the "AV IN 1 (VIDEO)" (or "AV IN 2 (VIDEO)") jack on the TV and the VIDEO OUT jack on the VCR.

Follow the instructions in "Viewing a VCR or Camcorder Tape" to view your VCR tape.

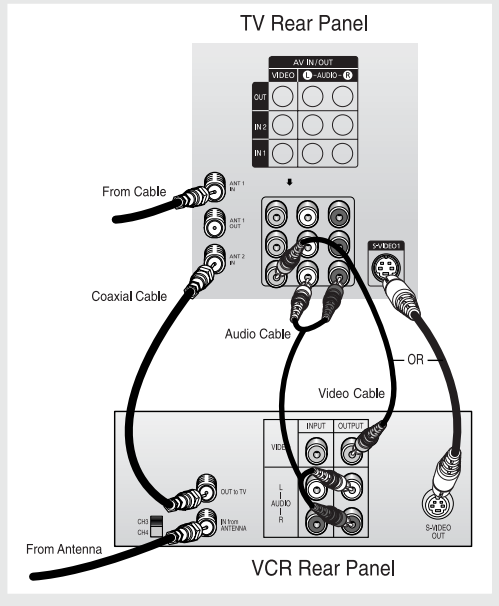

- Also, you can connect to "AV 3" on the side panel of TV.

## Connecting a Second VCR to Record from the TV

Your TV can send out signals of its picture and sound to be recorded by a second VCR. To do this, connect your second VCR as follows:

### 1

Connect a set of audio cables between the "AV OUT (L, R)" jacks on the TV and the AUDIO IN jacks on the VCR.

(The VCR input jacks might be either on the front or rear of the VCR.)

### 2

Connect a video cable between the "AV OUT (VIDEO)" jack on the TV and the VIDEO IN jack on the VCR.

Refer to your VCR's instructions for more information about how to record using this kind of connection.

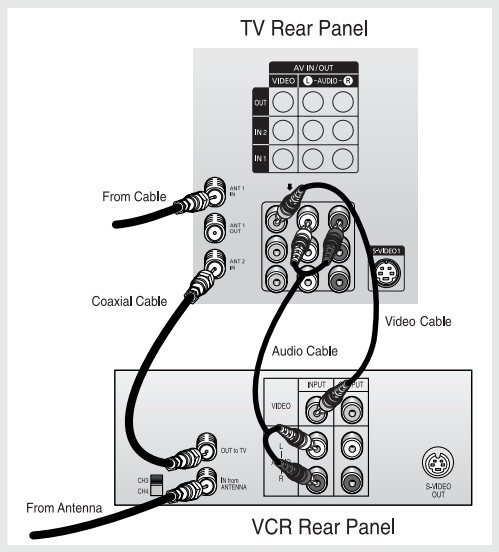

## Connecting a DVD Player

The rear panel jacks on your TV make it easy to connect a DVD player to your TV.

### Connecting to Y, Pb, Pr

**1**

Connect a set of audio cables between the “COMPONENT IN 1 (L, R)” (or “COMPONENT IN 2 or 3 (L, R)”) jacks on the TV and the AUDIO OUT jacks on the DVD player.

**2**

Connect a set of video cables between the “COMPONENT IN 1 (Y, Pb, Pr)” (or “COMPONENT IN 2 or 3 (Y, Pb, Pr)”) jacks on the TV and the VIDEO OUT (Y, Pb, Pr) jacks on the DVD player.

For an explanation of Component video, see your DVD player’s owner’s instruction.

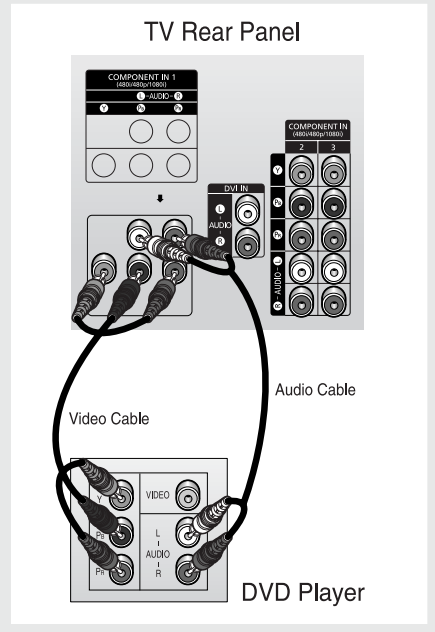

### Connecting to Regular Audio and Video jacks

**1**

Connect a set of audio cables between the “AV IN 1 (L, R)” (or “AV IN 2 (L, R)”) jacks on the TV and the AUDIO OUT jacks on the DVD player.

**2**

Connect a video cable between the “AV IN 1 (VIDEO)” (or “AV IN 2 (VIDEO)”) jack on the TV and the VIDEO OUT jack on the DVD player.

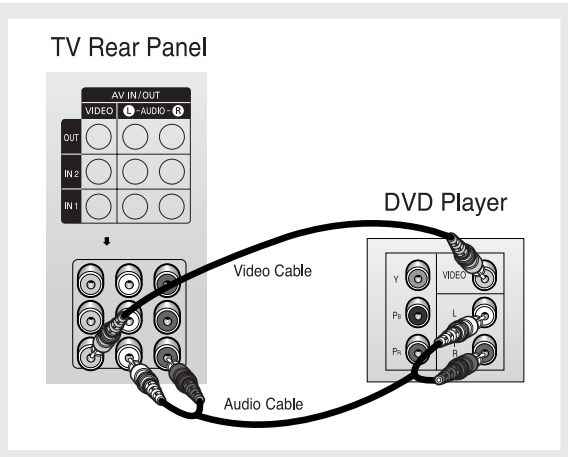

- Also, you can connect to “AV 3” on the side panel of TV.

## Connecting a Digital TV Set-Top Box

The rear panel jacks on your TV make it easy to connect a Set-Top Box to your TV.

### Connecting to Y, PB, PR

**1**

Connect a coaxial cable to the ANTENNA IN terminal on the Set-Top Box.

**2**

Connect a set of audio cables between the "COMPONENT IN 1 (L, R)" (or "COMPONENT IN 2 or 3 (L, R)") jacks on the TV and the AUDIO OUT jacks on the Set-Top Box.

**3**

Connect a set of video cables between the "COMPONENT IN 1 (Y, PB, PR)" (or "COMPONENT IN 2 or 3 (Y, PB, PR)") jacks on the TV and the VIDEO OUT (Y, PB, PR) jacks on the Set-Top Box.

The connections for a typical Set-Top Box are shown. For detailed information, refer to the Set-Top Box instruction manual.

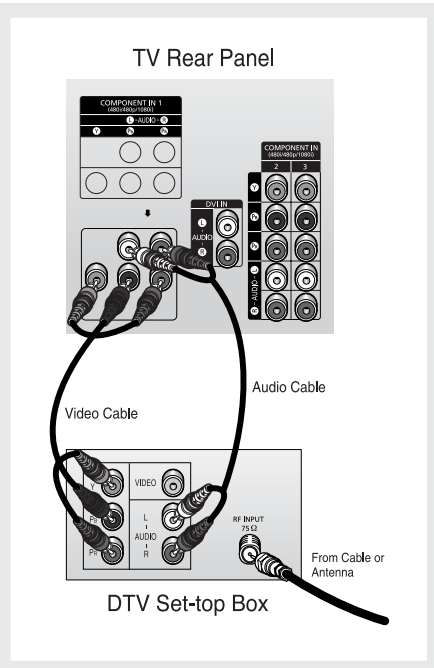



## Connecting to DVI (Digital Visual Interface)

By inputting a high-bandwidth digital content protection high-definition picture source to the DIGITAL INPUT jack on the TV, high-definition pictures can be displayed on the screen in their digital forms. (This DIGITAL INPUT jack is for use in the future when high-bandwidth digital content protection DTV decoders, DVD players and D-VHS are put on the market.)

**1**

Connect a set of audio cables between the “DVI IN (AUDIO-L, R)” jacks on the TV and the AUDIO OUT jacks on the Set-Top Box.

**2**

Connect a video cable between the “HDMI/DVI IN” jack on the TV and the VIDEO OUT jack on the Set-Top Box.

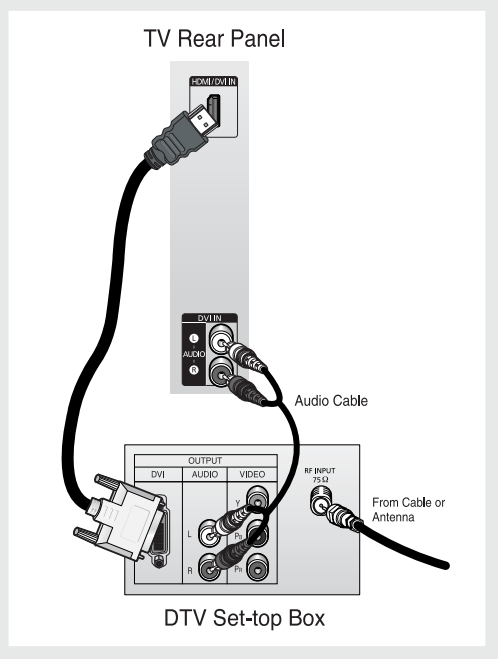

- The DIGITAL INPUT jack can only be used with 1080i and 480p picture signals. Set the DTV decoder DIGITAL OUTPUT jack output setting to 1080i or 480p. The DIGITAL INPUT jack is not compatible with the picture signal of a PC.

## Connecting to HDMI (High Definition Multimedia Interface)

Connect a HDMI cable between the “HDMI/DVI IN” jacks on the TV and the HDMI OUT jacks on the Set-Top Box.

Please check that the HDMI source is powered on. If not, you can not select “HDMI” in the “Source List” on-screen menu.

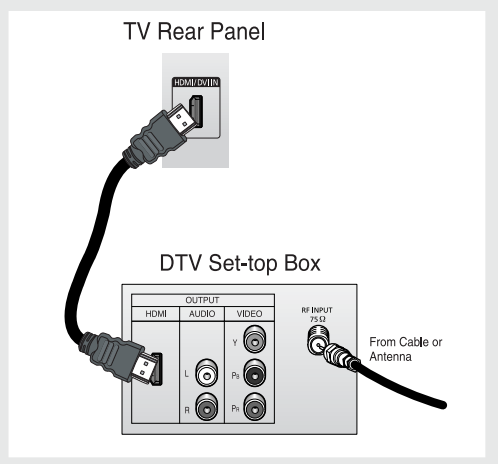

## Connecting a Camcorder

The side panel jacks on your TV make it easy to connect a camcorder to your TV. They allow you to view the camcorder tapes without using a VCR. (Also see “Viewing an External Signal Source” on page 39).

### 1

Locate the A/V output jacks on the camcorder. They are usually found on the side or rear of the camcorder.

### 2

Connect a set of audio cables between the “AV 3 (L, R)” jacks on the TV and the AUDIO OUT jacks on the camcorder. If you have mono camcorder, connect L(mono) to camcorder audio out using only one audio cable.

### 3

Connect a video cable between the “AV 3 (VIDEO)” (or “S-VIDEO”) jack on the TV and the VIDEO OUT jacks on the camcorder.

The audio-video cables shown here are usually included with a Camcorder. (If not, check your local electronics store.) If your camcorder is stereo, you need to connect a set of two cables.

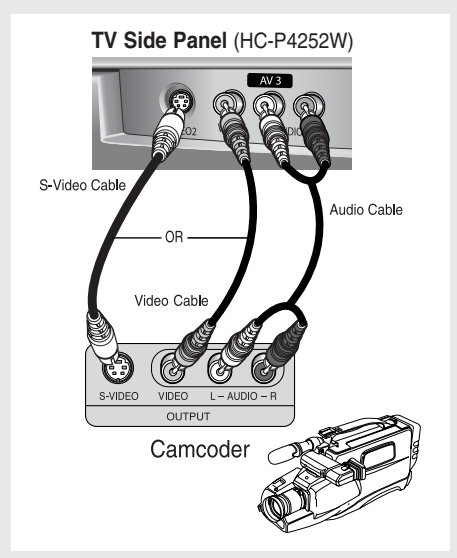

- This figure shows the Standard connector-jack panel. The actual configuration for your TV may be different.

## Installing Batteries in the Remote Control

**1**

Slide the back cover all the way out to open the battery compartment of the remote control.

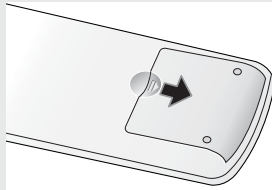

**2**

Install two AAA size batteries.

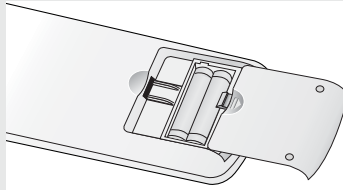

◀ Make sure to match the “+” and “-” ends of the batteries with the diagram inside the compartment.

**3**

Replace the cover.

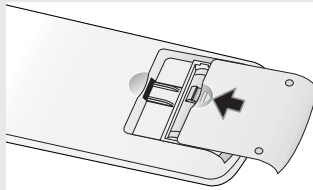

◀ Remove the batteries and store them in a cool, dry place if you won't be using the remote control for a long time. (Assuming typical TV usage, the batteries last for about one year.)

- The remote control can be used up to about 23 feet from the TV.

# Chapter Three

## OPERATION

### Turning the TV On and Off

Press the **POWER** button on the remote control.  
You can also use the **POWER** button on the front panel.

### Plug & Play Feature

When the TV is initially powered On, basic customer settings proceed automatically and subsequently as below.

**1**

Press the **POWER** button on the remote control.  
The "Start Plug & Play" is displayed.  
Press the **ENTER** button to start.



◀ Plug & Play feature doesn't work when the V-Chip is activated or when in the A/V mode.

**2**

The "Language" menu is displayed.  
Press the ▲ or ▼ button to select the appropriate language, then press the **ENTER** button.



**3**

The "Check antenna input" is displayed.  
Make sure that the antenna is connected to the TV, then press the **ENTER** button.

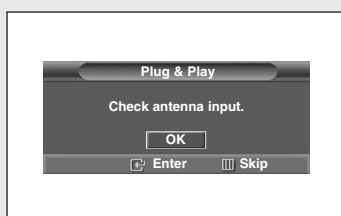

**4**

The "Air/CATV" menu is displayed.  
Press the ▲ or ▼ button to select the video signal source, then press the **ENTER** button.

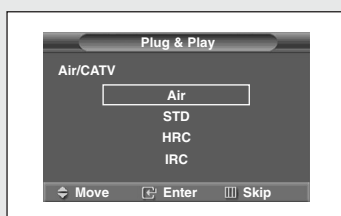

## 5

The "Auto Program" menu is displayed.  
Press the **ENTER** button to start the auto program.  
The TV begins memorizing all of the available stations.

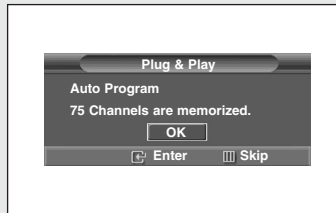

◀ For details, see page 27.

## 6

When it has finished, the "Clock Set" menu is displayed.  
Set the clock.

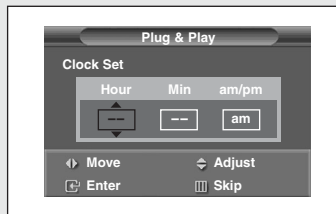

◀ For details, see page 36.

## 7

When you have finished, press the **ENTER** button.  
The message "Enjoy your watching." is displayed.



## 8

**If you want to reset this feature:**  
Press the **MENU** button.  
Press the **▲** or **▼** button to select "Setup", then press the **ENTER** button.  
Press the **▲** or **▼** button to select "Plug & Play", then press the **ENTER** button.  
The "Start Plug & Play" is displayed.



## Viewing the Menus and On-Screen Displays

### Viewing the Menus

**1**

Press the **MENU** button.  
The main menu is displayed.  
There are five menu groups:  
"Input", "Picture", "Sound",  
"Channel" and "Setup".



**2**

Press the **▲** or **▼** button to move  
to an item you want in the menu.  
Press the **◀** or **▶** button to  
display, change or use the  
selected items.  
Press the **ENTER** button to enter  
items in the menu.

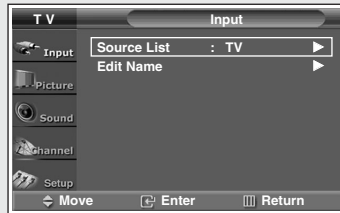

◀ You can also use the **MENU**,  
**CH▲/▼**, **VOL+/-** and  
**ENTER** buttons on the  
control panel of the TV to make  
selections.

**3**

Press the **EXIT** button to exit.

### Viewing the Display

Press the **INFO** button on the  
remote control.  
The TV displays the current  
channel, the status of certain  
picture and sound settings and  
the current time.

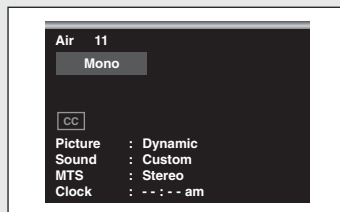

## Selecting a Menu Language

**1**

Press the **MENU** button.  
Press the **▲** or **▼** button to select "Setup", then press the **ENTER** button.



**2**

Press the **▲** or **▼** button to select "Language", then press the **ENTER** button.

Press the **▲** or **▼** button to select the appropriate language, then press the **ENTER** button.

Press the **EXIT** button to exit.



## Selecting the Antenna Input

You can connect two different signal sources by choosing the antenna input ("Ant.1" or "Ant.2").

**1**

Press the **MENU** button.  
Press the **▲** or **▼** button to select "Channel", then press the **ENTER** button.



**2**

Press the **ENTER** button to select "Antenna".

Press the **▲** or **▼** button to select "Ant.1" or "Ant.2", then press the **ENTER** button.

Press the **EXIT** button to exit.



## Adjusting the Screen Automatically (Self Focus)

The “Self Focus” feature automatically finds the optimum picture quality when blurring, overlapping colors or incorrect focus occurs. These conditions may be caused by moving your TV.

### 1

Press the **MENU** button.  
Press the **▲** or **▼** button to select “Setup”, then press the **ENTER** button.



### 2

Press the **▲** or **▼** button to select “Self Focus”, then press the **ENTER** button.  
The “Self Focus” is selected.

Press the **ENTER** button again.  
The self focus process begins with the message “Self Focus” and horizontal bar is displayed.  
When it is finished, all of things will disappear and the optimum picture quality can be enjoyed.

Press the **EXIT** button to exit.



◀ During the process, minor distortions of the picture may occur. At this time, the colors may diffuse and a searching pattern will appear on the edges of the screen. This is a normal part of the adjustment.

#### Alternate method:

Simply press the **SELF FOCUS** button on the remote control to enjoy the optimum picture quality.



- Changing channels and any other signal changes will pause the self focus until a stable signal has returned. It resumes after the signal has been stabilised. This feature will not work without a signal
- Ambient light that is too bright may affect the self focus. If this occurs, darken the environment and try again.



## Deactivating the Automatic Execution of the Self Focus

The “Self Focus” feature starts on default. It will automatically begin 10 minutes after switching on the power and the appearance of the screen image. To set the optimum picture quality, the “Self Focus” will automatically begin again after another 30 minutes, as the screen image is then fully stabilised.

**1**

Press the **MENU** button.  
Press the **▲** or **▼** button to select “Setup”, then press the **ENTER** button.



**2**

Press the **▲** or **▼** button to select “Self Focus”, then press the **ENTER** button.

Press the **▲** or **▼** button to select “Auto”, then press the **ENTER** button.

To turn off the automatic execution of the self focus feature, select “Off” by pressing the **▲** or **▼** button, then press the **ENTER** button.



## Removing the “Self Focus” Message from the Display

**3**

Press the **▲** or **▼** button to select “Message Display”, then press the **ENTER** button.  
To remove the message “Self Focus” and horizontal bar on the screen during the self focus process, select “Off” by pressing the **▲** or **▼** button, then press the **ENTER** button.

Press the **EXIT** button to exit.



## Memorizing the Channels

Your TV can memorize and store all of the available channels for both “off-air” (antenna) and cable channels. After the available channels are memorized, use the **CH▲** and **CH▼** buttons to scan through the channels. This eliminates the need to change channels by entering the channel digits.

### Selecting the Video Signal Source

Before your TV can begin memorizing the available channels, you must specify the type of signal source that is connected to the TV (i.e., an antenna or a cable system).

# 1

Press the **MENU** button.  
Press the **▲** or **▼** button to select “Channel”, then press the **ENTER** button.



# 2

Press the **▲** or **▼** button to select “Air/CATV”, then press the **ENTER** button.

Press the **▲** or **▼** button to select “Air”, “STD”, “HRC” or “IRC”, then press the **ENTER** button.

Press the **EXIT** button to exit.



◀ If you are connected to an antenna, press the **▲** or **▼** button to select “Air”.

◀ If you connected cable, press the **▲** or **▼** button to select the type of cable system: “STD”, “HRC” or “IRC”.

- “STD”, “HRC” and “IRC” identify various types of cable TV systems. Contact your local cable company to identify the type of cable system that exists in your particular area. At this point the signal source has been selected. Proceed to “Storing Channels in Memory”.
- Subscription cable services require service-specific requirement for viewing.

## Storing Channels in Memory (Automatic Method)

First, select the correct signal source (“Air”, “STD”, “HRC” or “IRC”) as described on the previous page.

**1**

Press the **MENU** button.  
Press the **▲** or **▼** button to select “Channel”, then press the **ENTER** button.



**2**

Press the **▲** or **▼** button to select “Auto Program”, then press the **ENTER** button.

Press the **ENTER** button to start the auto program.

The TV begins memorizing all of the available stations.

Press the **ENTER** button at any time to interrupt the memorization process.

Press the **EXIT** button to exit.

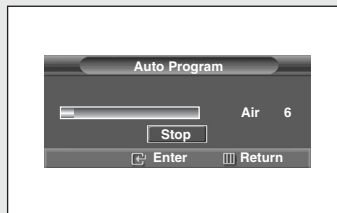
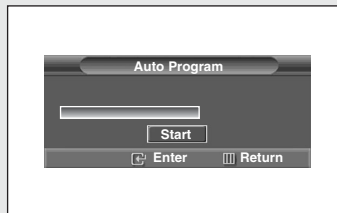

## Adding and Erasing Channels

To add channels that were not memorized (or to delete unwanted channels from memory):

**1**

Press the **MENU** button.  
Press the **▲** or **▼** button to select "Channel", then press the **ENTER** button.



**2**

Press the **▲** or **▼** button to select "Add/Delete", then press the **ENTER** button.

Repeatedly pressing the **ENTER** button will alternate between add channel and delete channel. Press the **CH▲** or **CH▼** button to switch to the appropriate channel, then repeat above.

Press the **EXIT** button to exit.

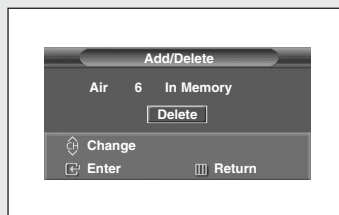
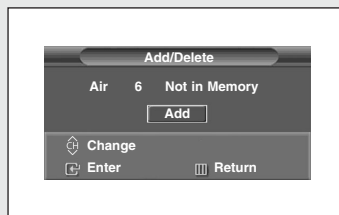

### Alternate method:

Simply press the **ADD/DEL** button on the remote control to add channels that were not memorized or to delete unwanted channels from memory.

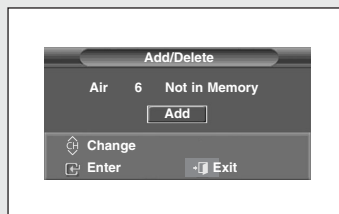

## Changing Channels

### Using the Channel Buttons

Press the **CH $\wedge$**  or **CH $\vee$**  button to change channel.

When you press the **CH $\wedge$**  or **CH $\vee$**  button, the TV changes channels in sequence. You will see all the channels that the TV has memorized. (The TV must have memorized at least three channels.) You will not see channels that were either erased or not memorized.

### Using the Number Buttons

Use the number buttons to quickly tune to any channel.

Press the number buttons to go directly to a channel.  
For example, to select channel "27", press the "2", then "7". The TV will change channels when you press the second number.

When you use the number buttons, you can directly select channels that were either erased or not memorized.

To select a channel over 100, press the **+100** button. (For channel "122", press the **+100** button, then "2", then "2".)

To change to single-digit channels (0–9) faster, press the "0" before the single digit. (For channel "4", press the "0", then "4".)

### Using the Previous Channel

Press the **PRE-CH** button.  
The TV changes to the last channel you were watching.



## Selecting Your Favorite Channels

You can store your favorite channels for each available input source (such as TV and CATV), This allows you to quickly and easily find frequently watched channels by pressing the **FAV.CH** button on the remote control.

### To Store Your Favorite Channels:

**1**

Press the **MENU** button.  
Press the **▲** or **▼** button to select "Channel", then press the **ENTER** button.



**2**

Press the **▲** or **▼** button to select "Favorite Channels", then press the **ENTER** button.

Press the **▲** or **▼** button to select a channel, then press the **ENTER** button.

Press the **ENTER** button again to deselect the selected channel.

Press the **EXIT** button to exit.

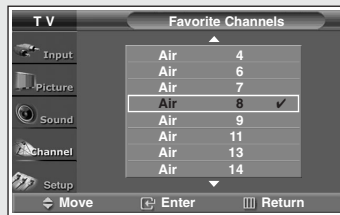

◀ Only memorized channels can be set as Favorite channels.

### To View Your Favorite Channels:

Press the **FAV.CH** button repeatedly to jump from one favorite channel to another.



## Labeling the Channels

Use this feature to assign an easy-to-remember label to any channel (i.e., “CBS”, “ESPN”, “PBS2”, CNN1”, etc.) A label consists of five fields, where each field is a letter, a number or a blank. When the **INFO** button is pressed, the channel label will appear next to the channel number.

### 1

Press the **CH**▲ or **CH**▼ button to tune to the channel that will be labeled.

### 2

Press the **MENU** button.  
Press the ▲ or ▼ button to select “Channel”, then press the **ENTER** button.



### 3

Press the ▲ or ▼ button to select “Name”, then press the **ENTER** button.

Press the ▲ or ▼ button to select the channel to be assigned to a new name, then press the **ENTER** button.

Press the ▲ or ▼ button to select a letter, a number or a blank. (Results in this sequence: A...Z, -, 0...9, blank, \*).

Press the ► button to switch to the next field, which will be selected.

Select a second letter or digit pressing ▲ or ▼ button, as above. Repeat the process to select the last two digits.

When you have finished, press the **ENTER** button.

Press the **EXIT** button to exit.

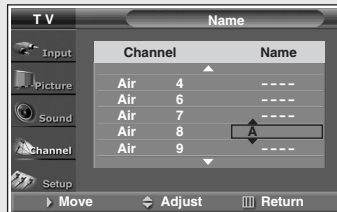

◀ If you add or delete the TV channel, the labeled channels list will also be added or deleted.

## Picture Control

You can use the on-screen menus to change the “Contrast”, “Brightness”, “Sharpness”, “Color” and “Tint” according to personal preference. (Alternatively, you can use one of the automatic settings. See next page.)

### Customizing the Picture

**1**

Press the **MENU** button.  
Press the **▲** or **▼** button to select “Picture”, then press the **ENTER** button.

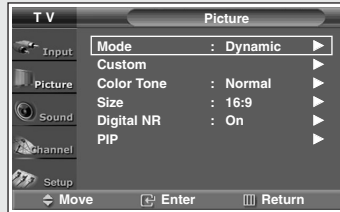

**2**

Press the **▲** or **▼** button to select “Custom”, then press the **ENTER** button.

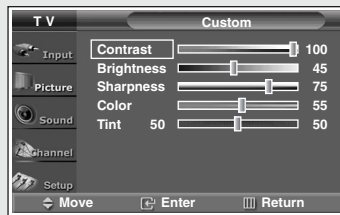

**3**

Press the **▲** or **▼** button to select a particular item, then press the **ENTER** button.

Press the **◀** or **▶** button to increase or decrease the value of a particular item.

Press the **EXIT** button to exit.





## Using Automatic Picture Settings

Your TV has automatic picture settings (“Dynamic”, “Standard” and “Movie”) that are preset at the factory. You can activate either “Dynamic”, “Standard” or “Movie” by pressing the **P.MODE** button (or by making a selection from the menu). Or, you can select “Custom” which automatically recalls your personalized picture settings.

### 1

Press the **MENU** button.  
Press the **▲** or **▼** button to select “Picture”, then press the **ENTER** button.

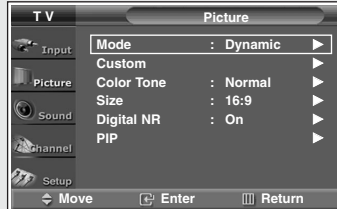

### 2

Press the **ENTER** button to select “Mode”.

Press the **▲** or **▼** button to select a particular item, then press the **ENTER** button.

Press the **EXIT** button to exit.

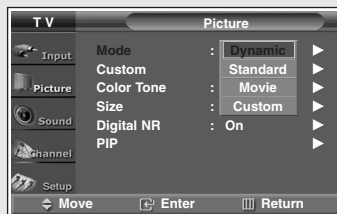

#### Alternate method:

Press the **P.MODE** button on the remote control repeatedly to select one of the standard picture settings.



- Choose **Dynamic** for viewing the TV during the day or when there is a bright light in the room.
- Choose **Standard** for the standard factory settings.
- Choose **Movie** when viewing a movie.
- Choose **Custom** if you want to adjust the settings according to personal preference (see previous page).

## Sound Control

### Adjusting the Volume

Press the **VOL +** or **VOL -** buttons to increase or decrease the volume.

### Using the MUTE Button

At any time, you can temporarily cut off the sound by using the **MUTE** button.

**1**

Press the **MUTE** button on the remote control.  
The message "Mute" is displayed and the sound cuts off.



**2**

To turn mute off press the **MUTE** button again or, press either the **VOL-** or **VOL+** button.

### Customizing the Sound

The sound settings can be adjusted to suit your personal preference. (Alternatively, you can use one of the automatic settings. See next page.)

**1**

Press the **MENU** button.  
Press the **▲** or **▼** button to select "Sound", then press the **ENTER** button.



**2**

Press the **▲** or **▼** button to select "Equalizer", then press the **ENTER** button.

Press the **◀** or **▶** button to select a particular item to be changed.

Press the **▲** or **▼** button to increase or decrease the value of a particular item.

Press the **EXIT** button to exit.

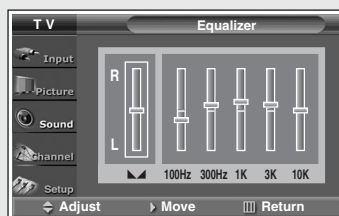

## Using Automatic Sound Settings

Your TV has automatic sound settings (“Standard”, “Music”, “Movie” and “Speech”) that are preset at the factory. You can activate these sound settings by pressing the **S.MODE** button (or by making a selection from the menu), or you can select “Custom”, which automatically recalls your personalized sound settings.

### 1

Press the **MENU** button.  
Press the **▲** or **▼** button to select “Sound”, then press the **ENTER** button.



### 2

Press the **ENTER** button to select “Mode”.

Press the **▲** or **▼** button to select a particular item, then press the **ENTER** button.

Press the **EXIT** button to exit.



#### Alternate method:

Press the **S.MODE** button on the remote control repeatedly to select one of the standard sound settings.

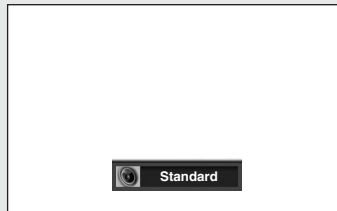

- Choose **Standard** for the standard factory settings.
- Choose **Music** when watching music videos or concerts.
- Choose **Movie** when watching movies.
- Choose **Speech** when watching a show that is mostly dialogue (i.e., news).
- Choose **Custom** to recall your personalized settings.

## Setting the Clock

Setting the clock is necessary in order to use the various timer features of the TV. Also, you can check the time while watching the TV. (Just press the **INFO** button.)

### Option 1: Setting the Clock Manually

#### 1

Press the **MENU** button.  
Press the **▲** or **▼** button to select "Setup", then press the **ENTER** button.



#### 2

Press the **ENTER** button to select "Time".

Press the **ENTER** button to select "Clock".



#### 3

Press the **ENTER** button to select "Clock Mode".

Press the **▲** or **▼** button to select "Manual", then press the **ENTER** button.

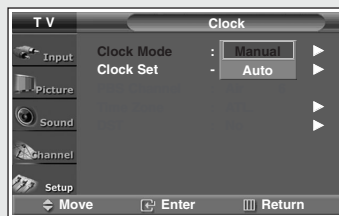

#### 4

Press the **▲** or **▼** button to select "Clock Set", then press the **ENTER** button.

Press the **◀** or **▶** button to move to "Hour", "Min" or "am/pm". Set the clock you want by pressing the **▲** or **▼** button, then press the **ENTER** button.

Press the **EXIT** button to exit.



◀ The current time will appear every time you press the **INFO** button.

◀ You can set the hour and minute directly by pressing the number buttons on the remote control.

## Option 2: Setting the Clock Automatically

The Clock can be set automatically if you are receiving a digital signal.

**1**

Press the **MENU** button.  
Press the **▲** or **▼** button to select "Setup", then press the **ENTER** button.



**2**

Press the **ENTER** button to select "Time".

Press the **ENTER** button to select "Clock".



**3**

Press the **ENTER** button to select "Clock Mode".

Press the **▲** or **▼** button to select "Auto", then press the **ENTER** button.



◀ Certain broadcasts may not transmit the correct time. In this case, set the time manually.

**4**

Press the **▲** or **▼** button to select "PBS Channel", then press the **ENTER** button.  
Press the **▲** or **▼** button to select your local PBS channel, then press the **ENTER** button.



continued...

## 5

Press the ▲ or ▼ button to select “Time Zone”, then press the **ENTER** button.

Press the ▲ or ▼ button to select the time zone for your local area, then press the **ENTER** button.



- ATL. : Atlantic
- EAST : Eastern
- CEN. : Central
- MTN. : Mountain
- PAC. : Pacific
- ALAS. : Alaska
- HAW. : Hawaii

◀ The set time can be changed according to the broadcasting station and signal when you set up auto time.

If there is a difference between the real time and set time, please set up manual time.

## 6

Press the ▲ or ▼ button to select “DST” (Daylight Saving Time), then press the **ENTER** button.

Press the ▲ or ▼ button to select “Yes” or “No”, then press the **ENTER** button.



Press the **EXIT** button to exit.

## Viewing an External Signal Source

Use the remote control to switch between viewing signals from connected equipment, such as VCR, DVD, Set-Top box and the TV source (broadcast or cable).

### Setting the Signal Source

# 1

Press the **MENU** button.  
Press the **ENTER** button to select  
"Input".

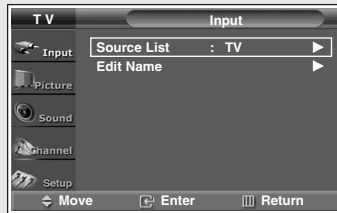

# 2

Press the **ENTER** button to select  
"Source List".

Press the **▲** or **▼** button to  
select a signal source, then  
press the **ENTER** button.

Press the **EXIT** button to exit.



◀ When you connect equipment to the TV, you can choose between the following sets of jacks : "AV3", "S-Video2" on the TV's side panel or "AV1", "AV2", "S-Video1", "Component1", "Component2", "Component3" or "HDMI" on the TV's rear panel.

#### Alternate method:

Press the **SOURCE** button on the remote control repeatedly to select an external signal source.



## Assigning Names to External Sources

This feature enables you to name the input source you have connected.

**1**

Press the **MENU** button.  
Press the **ENTER** button to select "Input".



**2**

Press the **▲** or **▼** button to select "Edit Name", then press the **ENTER** button.

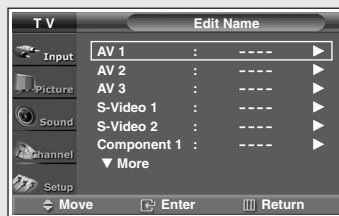

**3**

Press the **▲** or **▼** button to select a signal source, then press the **ENTER** button.  
Press the **▲** or **▼** button to select an external device, then press the **ENTER** button.



Press the **EXIT** button to exit.

◀ The device names available are listed.

- VCR
- DVD
- Cable STB
- HD STB
- Satellite STB
- AV Receiver
- DVD Receiver
- Game
- Camcorder
- DVD Combo
- DHR (DVD HDD Recorder)
- PC



# Chapter Four

## SPECIAL FEATURES

### Fine Tuning Channels

The Fine Tuning function lets you manually adjust the TV's tuner if you have difficulty tuning channels.

**1**

Press the **MENU** button.  
Press the **▲** or **▼** button to select "Channel", then press the **ENTER** button.



**2**

Press the **▲** or **▼** button to select "Fine Tune", then press the **ENTER** button.

Press the **◀** or **▶** button to adjust the fine tuning.  
To store the fine tuning setting in the TV's memory, press the **ENTER** button. The symbol "\*" is displayed.

To reset the fine tuning to "0", select "Reset" by pressing the **▲** or **▼** button, then press the **ENTER** button.

Press the **EXIT** button to exit.

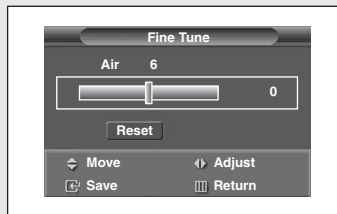

## Scanning the Channels

The TV automatically scan all of the channels it has memorized.

**1**

Press the **MENU** button.  
Press the **▲** or **▼** button to select "Channel", then press the **ENTER** button.



**2**

Press the **▲** or **▼** button to select "Scan", then press the **ENTER** button.  
The TV scans all of the channels memorized.

Press the **EXIT** button to exit.

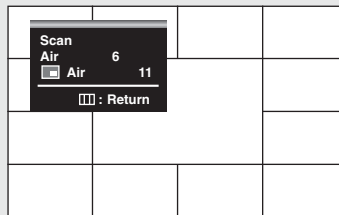

◀ When the "ANT 2 IN" mode is selected, the channel scan function works on the main picture only.

## Selecting the Color Tone

### 1

Press the **MENU** button.  
Press the **▲** or **▼** button to select "Picture", then press the **ENTER** button.

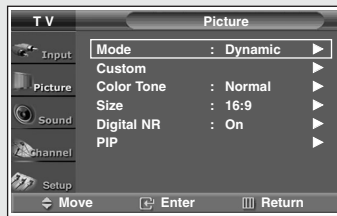

### 2

Press the **▲** or **▼** button to select "Color Tone", then press the **ENTER** button.

Press the **◀** or **▶** button to increase or decrease the value of the color tone ("Warm 10~1", "Normal" and "Cool 1~10").

Press the **EXIT** button to exit.

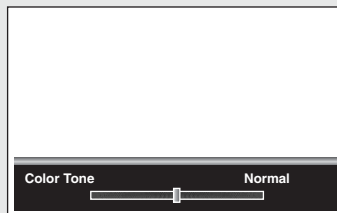

## Changing the Picture Size

**1**

Press the **MENU** button.  
Press the **▲** or **▼** button to select "Picture", then press the **ENTER** button.

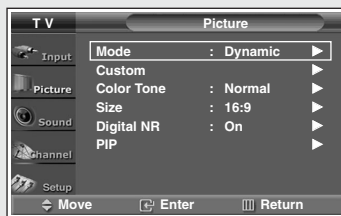

**2**

Press the **▲** or **▼** button to select "Size", then press the **ENTER** button.

Press the **▲** or **▼** button to select the screen format you want.

Press the **EXIT** button to exit.



◀ In the "Zoom 1" and "Zoom 2" modes, lifting is available by pressing the **▲** or **▼** button.

◀ Captions or subtitles might be interrupted in the "Cinematic" and "Cinema2" modes.

### Alternate method:

Press the **P.SIZE** button on the remote control repeatedly to select one of the screen format you want.

### Viewing with a 4:3 signal (When a 4:3 signal is received)

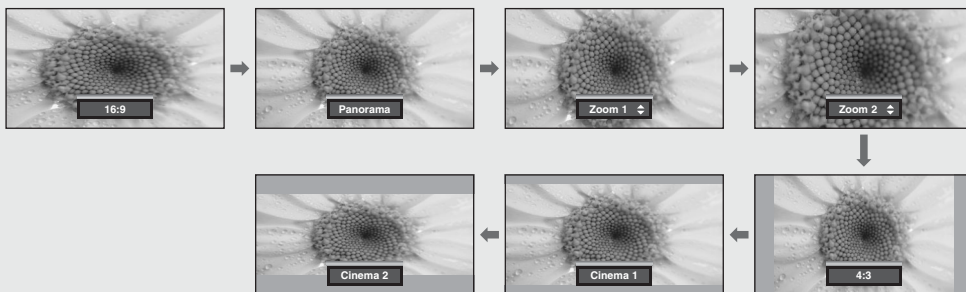

### Viewing with a 16:9 signal (When a 16:9 signal is received)

The illustrations below show the change of picture while viewing a DVD title.

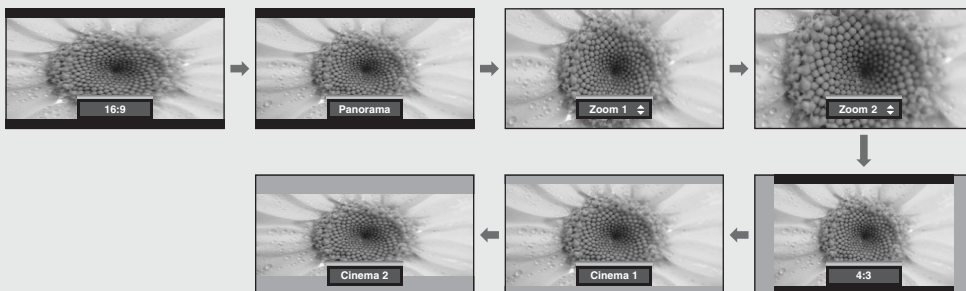

## Digital Noise Reduction

If the broadcast signal received by your TV is weak, you can activate this feature to help reduce any static and ghosting that may appear on the screen.

### 1

Press the **MENU** button.  
Press the **▲** or **▼** button to select "Picture", then press the **ENTER** button.

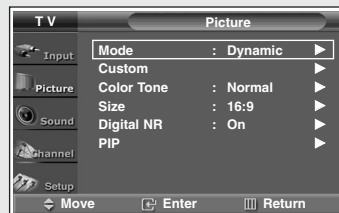

### 2

Press the **▲** or **▼** button to select "Digital NR", then press the **ENTER** button.  
Press the **▲** or **▼** button to select "On" or "Off", then press the **ENTER** button.

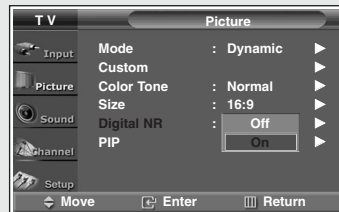

Press the **EXIT** button to exit.

## Viewing Picture-In-Picture

One of the most best features of your TV is the **Picture-In-Picture (PIP)** feature. The advanced **PIP** system allows you to watch two different pictures at once, even if you don't have a VCR connected to your TV.

### Activating the PIP

# 1

Press the **MENU** button.  
Press the **▲** or **▼** button to select "Picture", then press the **ENTER** button.

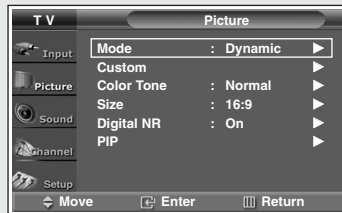

# 2

Press the **▲** or **▼** button to select "PIP", then press the **ENTER** button.

Press the **ENTER** button to select "PIP".

Press the **▲** or **▼** button to select "On", then press the **ENTER** button.

The sub picture appears in the corner of the screen.

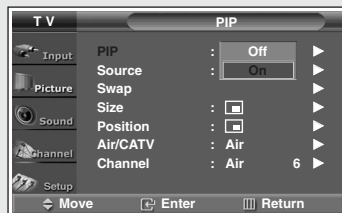

#### Alternate method:

Press the **PIP** button on the remote control repeatedly to activate or deactivate the PIP.

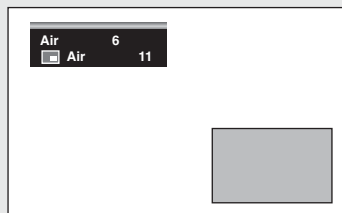

- This feature doesn't work when the "V-Chip" or "Caption" is active.
- If you turn the TV off while watching and turn it on again, then the mode will return to normal video.
- The picture size can't be changed when the "PIP" is active in the TV or AV mode.

### Selecting an External Source

#### 3

Press the ▲ or ▼ button to select “Source”, then press the **ENTER** button.

If you have not connected any equipment to the TV's input jacks, the signal from these inputs will not appear.

Press the ▲ or ▼ button to select an external signal, then press the **ENTER** button.

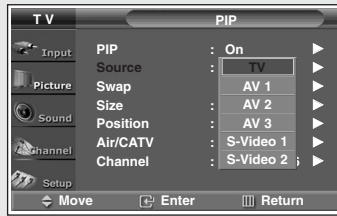

◀ For more information about external signals, see “Viewing an External Signal Source” (See page 39).

If you select “TV”, the sub picture is the same as the main picture.

◀ The sub picture doesn't support “ANT 2 IN”, “Component1”, “Component2”, “Component3” and “HDMI”.

### Swapping the Sub picture and Main picture

#### 4

Press the ▲ or ▼ button to select “Swap”, then press the **ENTER** button.

The sub picture appears in the main picture, and vice versa.

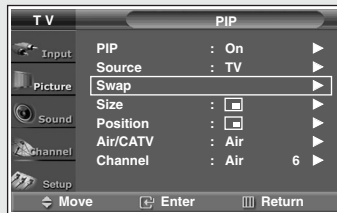

◀ The swapping doesn't support “ANT 2 IN”, “Component1”, “Component2”, “Component3” and “HDMI”.

◀ The swapping doesn't work in the “□□” (4PIP) and “□□□□” (13PIP) mode.

### Changing the Size of the Sub picture

#### 5

Press the ▲ or ▼ button to select “Size”, then press the **ENTER** button.

Press the ▲ or ▼ button to select a size you want, then press the **ENTER** button.

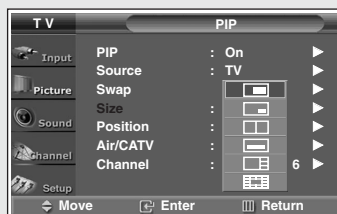

◀ “□□” (Double) function doesn't operate in the “HDMI” mode.

## Changing the Location of the Sub picture

### 6

Press the ▲ or ▼ button to select “Position”, then press the **ENTER** button.

Press the ▲ or ▼ button to select a position you want, then press the **ENTER** button.

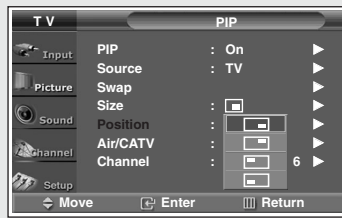

## Selecting a Signal Source for the Sub picture

If the source of the sub picture is “TV” during **PIP** on, you can select a signal source of the sub picture separately from the main picture. (If the main picture is “ANT 2 IN” and the signal sources are different, making adjustments is necessary.)

### 7

Press the ▲ or ▼ button to select “Air/CATV”, then press the **ENTER** button.

Press the ▲ or ▼ button to select “Air”, “STD”, “HRC” or “IRC”, then press the **ENTER** button.

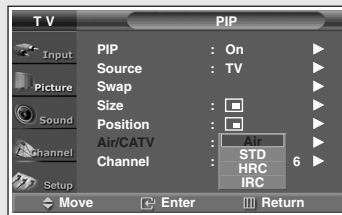



## Changing the Channel of the Sub picture

After you set the signal source (antenna or cable) of sub picture, it is easy to change channels.

**8**

Press the ▲ or ▼ button to select “Channel”, then press the **ENTER** button.

Press the ▲ or ▼ button to select a channel you want, then press the **ENTER** button.

Press the **EXIT** button to exit.



◀ The channels of sub picture are not available when antenna is set to “ANT 2 IN”. It links to “ANT 1 IN”.

### Alternate method:

Press the **CH▲** or **CH▼** button to change channels of sub picture during PIP on.

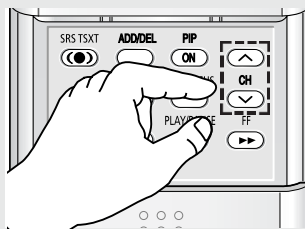

## Freezing the Picture

Press the **STILL** button to freeze a moving picture. (Normal sound will still be heard.)

Press again to cancel.

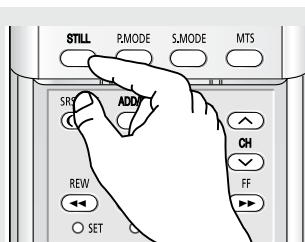

◀ The still function doesn't operate in “Component 1, 2, 3” mode.

## Choosing a Multi-Channel Sound (MTS) track

Depending on the particular program being broadcast, you can listen to “Mono”, “Stereo” or “SAP (Secondary Audio Program)”. “SAP” audio is usually a foreign-language translation. Sometimes “SAP” has unrelated information like news or weather.

### 1

Press the **MENU** button.  
Press the **▲** or **▼** button to select “Sound”, then press the **ENTER** button.



### 2

Press the **▲** or **▼** button to select “MTS”, then press the **ENTER** button.  
Press the **▲** or **▼** button to select a setting you want, then press the **ENTER** button.



Press the **EXIT** button to exit.

#### Alternate method:

Press the **MTS** button on the remote control repeatedly to select one of the settings.

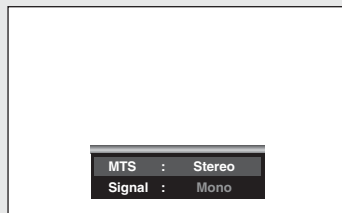

- Choose **Mono** for channels that are broadcasting in mono, or if you are having difficulty receiving a stereo signal.
- Choose **Stereo** for channels that are broadcasting in stereo.
- Choose **SAP** to listen to the Separate Audio Program, which is usually a foreign-language translation.

## Auto Volume

Each broadcasting station has its own signal conditions, and it is inconvenient to adjust the volume every time the channel is changed. “Auto Volume” automatically adjusts the volume of the desired channel by lowering the sound output when the modulation signal is high or by raising the sound output when the modulation signal is low.

### 1

Press the **MENU** button.  
Press the **▲** or **▼** button to select “Sound”, then press the **ENTER** button.



### 2

Press the **▲** or **▼** button to select “Auto Volume”, then press the **ENTER** button.  
Press the **▲** or **▼** button to select “On” or “Off”, then press the **ENTER** button.



Press the **EXIT** button to exit.

## Setting the SRS TSXT

TruSurround XT is a patented SRS technology that solves the problem of playing 5.1 multichannel content over two speakers. Trusurround delivers a compelling, virtual surround sound experience through any two-speaker playback system, including internal television speakers. It is fully compatible with all multichannel formats.

### 1

Press the **MENU** button.  
Press the **▲** or **▼** button to select "Sound", then press the **ENTER** button.



### 2

Press the **▲** or **▼** button to select "SRS TSXT", then press the **ENTER** button.  
Press the **▲** or **▼** button to select "Off", "3D Mono" or "Stereo", then press the **ENTER** button.



Press the **EXIT** button to exit.

#### Alternate method:

Press the **SRS TSXT** button on the remote control repeatedly to select one of the settings.

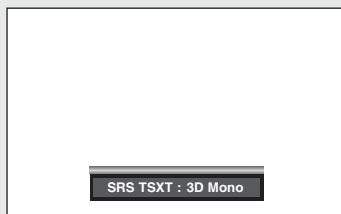

TruSurround XT, SRS and Symbol ((●●)) are trademarks of SRS Labs, Inc. TruSurround XT technology is incorporated under license from SRS Labs, Inc.

## Setting the On/Off Timer

### 1

Press the **MENU** button.  
Press the **▲** or **▼** button to select "Setup", then press the **ENTER** button.



### 2

Press the **ENTER** button to select "Time".

Press the **▲** or **▼** button to select "On Timer", then press the **ENTER** button.

Press the **▲** or **▼** button to adjust "Hour", then press the **▶** button to move to the next step. Set other items using the same method as above.

When finished, press the **MENU** button to return.

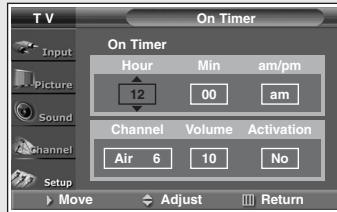

### 3

Press the **▲** or **▼** button to select "Off Timer", then press the **ENTER** button.

Press the **▲** or **▼** button to adjust "Hour", then press the **▶** button to move to the next step. Set other items using the same method as above.

Press the **EXIT** button to exit.

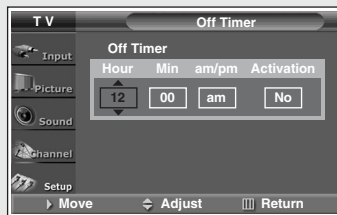

◀ The current time will appear every time you press the **INFO** button.

◀ You can set the hour and minute directly by pressing the number buttons on the remote control.

## Setting the Sleep Timer

The sleep timer automatically shuts off the TV after a preset time (from 30 to 180 minutes).

### 1

Press the **MENU** button.  
Press the **▲** or **▼** button to select "Setup", then press the **ENTER** button.



### 2

Press the **ENTER** button to select "Time".  
Press the **▲** or **▼** button to select "Sleep Timer", then press the **ENTER** button.  
Press the **▲** or **▼** button to select the preset time you want, then press the **ENTER** button.



Press the **EXIT** button to exit.

#### Alternate method:

Press the **SLEEP** button on the remote control repeatedly until the appropriate time interval appears (any of the preset values from "30Min" to "180Min").

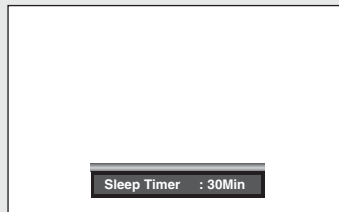

## Setting the Blue Screen Mode

If no signal is being received or the signal is very weak, a blue screen automatically replaces the noisy picture background. If you wish to continue viewing the poor picture, you must set the “Blue Screen” mode to “Off”.

### 1

Press the **MENU** button.  
Press the **▲** or **▼** button to select “Setup”, then press the **ENTER** button.



### 2

Press the **▲** or **▼** button to select “Blue Screen”, then press the **ENTER** button.  
Press the **▲** or **▼** button to select “On” or “Off”, then press the **ENTER** button.

Press the **EXIT** button to exit.



## Viewing Closed Caption Information

Your TV decodes and displays the closed captions information that is broadcast along with some television shows. These captions are usually subtitles for the hearing impaired or translations into other languages. All VCRs record the closed caption signal from television programs, so pre-recorded video tapes can also deliver closed-caption information. Check for the closed caption symbol (**CC**) on the tape's package or your TV program-schedule.

### 1

Press the **MENU** button.  
Press the **▲** or **▼** button to select "Setup", then press the **ENTER** button.



◀ The Caption function doesn't operate when the PIP is active.

### 2

Press the **▲** or **▼** button to select "Caption", then press the **ENTER** button.

Press the **ENTER** button to select "Caption".  
Press the **▲** or **▼** button to select "On", then press the **ENTER** button.



#### Alternate method:

Press the **CAPTION** button on the remote control repeatedly to select "On" or "Off".



### 3

Press the **▲** or **▼** button to select "Mode", then press the **ENTER** button.  
Press the **▲** or **▼** button to select "Caption" or "Text", then press the **ENTER** button.



◀ In "Caption" mode, caption appears at the bottom of the screen, and they usually cover only a small portion of the picture.

◀ In "Text" mode, information unrelated to the program, such as news or weather, is displayed. Text often covers a large portion of the screen.



**4**

Press the ▲ or ▼ button to select “Channel”, then press the **ENTER** button.  
Press the ▲ or ▼ button to select “1” or “2”, then press the **ENTER** button.

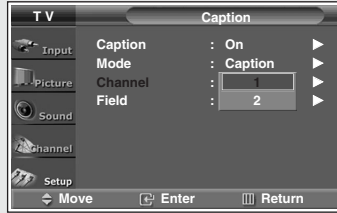

◀ Depending on the particular broadcast, it might be necessary to make changes to “Channel” and “Field”.

◀ Different channels and fields display different information: “Field 2” carries additional information that supplements the information in “Field 1”. (For example, “Channel 1” may have subtitles in English, while “Channel 2” has subtitles in Spanish.)

**5**

Press the ▲ or ▼ button to select “Field”, then press the **ENTER** button.  
Press the ▲ or ▼ button to select “1” or “2”, then press the **ENTER** button.



Press the **EXIT** button to exit.

- Misspellings and unusual characters sometimes occur during closed caption transmissions, especially those of live events. There may be a small delay before captions appear when you change channels. These are not malfunctions of the TV.

## Setting the On/Off Melody

A melody sound can be set to come on when the TV is powered On or Off.

**1**

Press the **MENU** button.  
Press the ▲ or ▼ button to select “Setup”, then press the **ENTER** button.



**2**

Press the ▲ or ▼ button to select “Melody”, then press the **ENTER** button.  
Press the ▲ or ▼ button to select “On” or “Off”, then press the **ENTER** button.



Press the **EXIT** button to exit.

## Selecting the HDMI Standard

This feature is for aligning the screen image center dislocated by the differences of various HDMI or DVI signal sources.

Initial setting is "861B". If you experience not aligned screen image center when the "HDMI/DVI IN" jack on the rear of your TV is used for external device, switch the setting to "SMPTE".

This feature only works when the external source is set to "HDMI". Refer to the "Viewing an External Signal Source" on the page 39 for further details.

### 1

Press the **MENU** button.  
Press the **▲** or **▼** button to select "Setup", then press the **ENTER** button.



### 2

Press the **▲** or **▼** button to select "HDMI Standard", then press the **ENTER** button.  
Press the **▲** or **▼** button to select "861B" or "SMPTE", then press the **ENTER** button.



Press the **EXIT** button to exit.

## Using the V-Chip

Access to channels and programs is controlled by a password (i.e., a 4-digit secret code that is defined by the user). The on-screen menu will instruct you to assign a password (and you can change it later, if necessary).

### How to Change Your Password

**1**

Press the **MENU** button.  
Press the **▲** or **▼** button to select "Setup", then press the **ENTER** button.



**2**

Press the **▲** or **▼** button to select "V-Chip", then press the **ENTER** button.

Press the number buttons to enter your current 4-digit pin number.

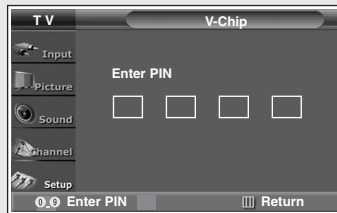

◀ The default pin number for a new TV set is "0 0 0 0".

◀ If you forget the pin number, press the remote control buttons in the following sequence, which resets the pin to 0-0-0-0:  
**POWER (Off)**, **MUTE**, **8**, **2**, **4**, **POWER (On)**.

**3**

The "V-Chip" menu is displayed.

Press the **▲** or **▼** button to select "Change PIN", then press the **ENTER** button.

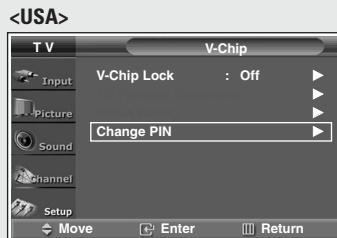

<Canada>

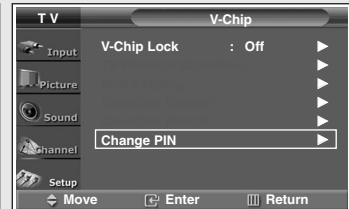

**4**

Press the number buttons to enter your new 4-digit pin number.  
Re-enter your new pin number to confirm.

Press the **EXIT** button to exit.

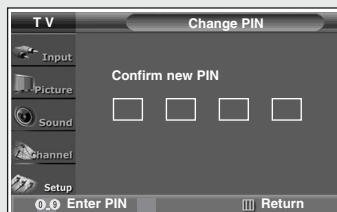
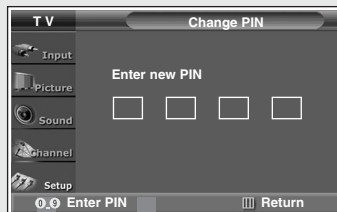

## How to Enable/Disable the Rating Controls

**1**

Press the **MENU** button.  
Press the **▲** or **▼** button to select "Setup", then press the **ENTER** button.



**2**

Press the **▲** or **▼** button to select "V-Chip", then press the **ENTER** button.

Press the number buttons to enter your current 4-digit pin number.

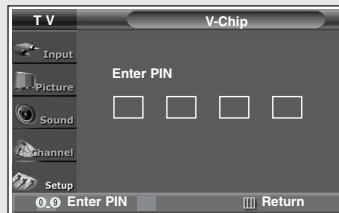

**3**

The "V-Chip" menu is displayed.

Press the **ENTER** button to select "V-Chip Lock".  
Press the **▲** or **▼** button to select "On", then press the **ENTER** button.

Press the **EXIT** button to exit.

<USA>

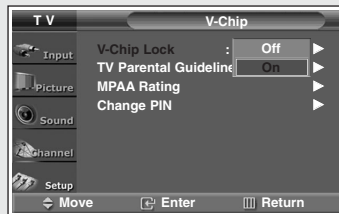

<Canada>



## How to Set up Restrictions Using the “TV Parental Guidelines”

The parental restrictions can be set up using either of two methods: The “TV Parental Guidelines” or “MPAA Rating”.

**1**

Press the **MENU** button.  
Press the **▲** or **▼** button to select “Setup”, then press the **ENTER** button.



**2**

Press the **▲** or **▼** button to select “V-Chip”, then press the **ENTER** button.

Press the number buttons to enter your current 4-digit pin number.

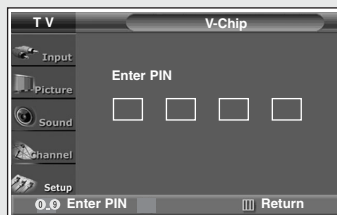

**3**

The “V-Chip” menu is displayed.

Press the **▲** or **▼** button to select “TV Parental Guidelines”, then press the **ENTER** button.

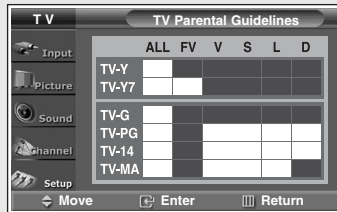

**4**

You can independently lock the TV ratings. The locked TV (FCC) ratings are indicated by the symbol “”.

Press the **▲/▼/◀/▶** button to select the appropriate restriction, then press the **ENTER** button.

Press the **EXIT** button to exit.

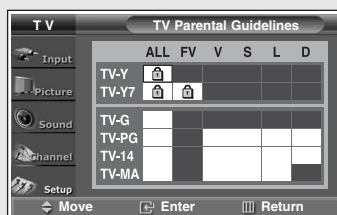

- ◀ **TV-Y** : Young children
- TV-Y7** : Children 7 and over

---

- TV-G** : General audience
- TV-PG** : Parent Guidance
- TV-14** : Viewers 14 and over
- TV-MA** : Mature Audience

- These categories consist of two separate groups: “TV-Y” and “TV-Y7” (young children through age 7), and “TV-G” through “TV-MA” (everybody else).
- The restrictions for these two groups work independently: If a household includes very young children as well as young adults, the TV parental guidelines must be set up separately for each age group. (See page 63.)

## How to Set up Restrictions Using the “MPAA Rating”

The Movie rating system uses the “MPAA” (Motion Picture Association of America) system, and its main application is for movies.

When the rating controls is on, the TV will automatically block any programs that are coded with objectionable ratings (either “MPAA Rating” or “TV Parental Guidelines”).

**1**

Press the **MENU** button.  
Press the **▲** or **▼** button to select “Setup”, then press the **ENTER** button.



**2**

Press the **▲** or **▼** button to select “V-Chip”, then press the **ENTER** button.

Press the number buttons to enter your current 4-digit pin number.

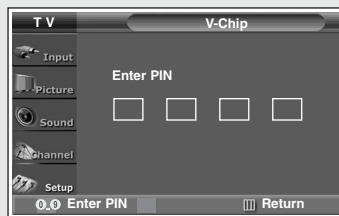

**3**

The “V-Chip” menu is displayed.

Press the **▲** or **▼** button to select “MPAA Rating”, then press the **ENTER** button.

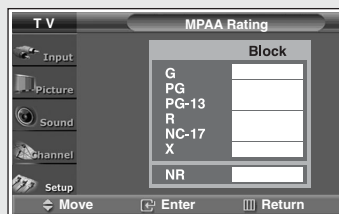

**4**

You can independently lock the movie ratings. The locked movie ratings are indicated by the symbol “”.

Press the **▲** or **▼** button to select the appropriate restriction, then press the **▶** or **ENTER** button.

Press the **EXIT** button to exit.

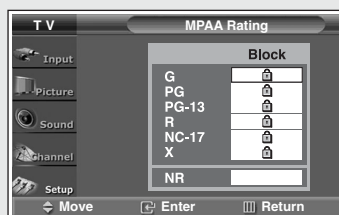

## Important Notes About Parental Locks

Explanation of the MPAA and TV (FCC) Rating Systems:

### TV (FCC) Age-Based Ratings

#### TV-MA

Mature audiences only. This program may contain mature themes, profane language, graphic violence and explicit sexual content.

#### TV-14

Parents strongly cautioned. This program may contain sophisticated themes, sexual content, strong language and more intense violence.

#### TV-PG

Parental guidance suggested. The program may contain infrequent coarse language, limited violence, some suggestive sexual dialogue and situations.

#### TV-G

General audience. It contains little or no violence, no strong language, and little or no sexual dialogue or situations.

#### TV-Y7

Directed to older children. Themes and elements in this program may include mild physical or comedic violence, or may frighten children under the age of seven.

#### TV-Y

All children. The themes and elements in this program are specifically designed for a very young audience, including children from ages two - six.

### TV (FCC) Content Category

- V** Violence.
- S** Sexual content.
- L** Offensive language.
- D** Dialogue sexual innuendo.
- FV** Fantasy or cartoon violence.

### MPAA Rating System (Movies)

- G** General audience. No restriction.
- PG** Children under 13 should be accompanied by an adult.
- PG-13** Parental guidance suggested. Children under 13 should be accompanied by an adult.
- R** Restricted. Viewers should be 17 or older.
- NC-17** Not classified. Viewers should be 17 or older.
- X** Adults only.
- NR** Not rated.

- TV (FCC) ratings : The particular rating that you have selected will be locked (and indicated as a red "L" on a blue background). Also, all of the age-based ratings will be locked within the particular group (i.e., "group 1" or "group 2"). Suppose that the TV-G rating and all of its contents (V, S, L, and D) are locked. In that case, more restrictive ratings (TV-PG, TV-14, and TV-MA) and all of their contents (V, S, L, and D) are automatically locked as well.
- MPAA ratings : The particular rating that you have selected will be locked. In addition, more restrictive ratings will be locked as well.
- Neither TV (FCC) ratings nor MPAA ratings apply to news programs.

## How to Set up Restrictions Using the “Canadian English”

**1**

Press the **MENU** button.  
Press the **▲** or **▼** button to select “Setup”, then press the **ENTER** button.



**2**

Press the **▲** or **▼** button to select “V-Chip”, then press the **ENTER** button.

Press the number buttons to enter your current 4-digit pin number.

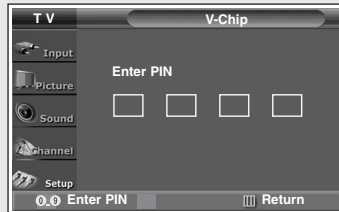

**3**

The “V-Chip” menu is displayed.

Press the **▲** or **▼** button to select “Canadian English”, then press the **ENTER** button.

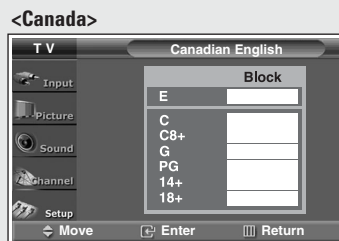

**4**

Press the **▲** or **▼** button to select the appropriate restriction, then press the **▶** or **ENTER** button.

Press the **EXIT** button to exit.

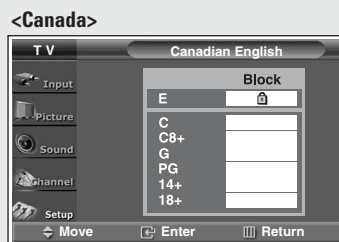

- E** Exempt programming includes...news, sports, documentaries and other information programming, talk shows, music videos, and variety programming.
- C** Programming intended for children under age 8.
- C8+** Programming generally considered acceptable for children 8 years and over to watch on their own.
- G** General programming, suitable for all audiences.
- PG** Parental Guidance.
- 14+** Programming contains themes or content which may not be suitable for viewers under the age of 14.
- 18+** Adult programming.



## How to Set up Restrictions Using the “Canadian French”

**1**

Press the **MENU** button.  
Press the **▲** or **▼** button to select “Setup”, then press the **ENTER** button.



**2**

Press the **▲** or **▼** button to select “V-Chip”, then press the **ENTER** button.

Press the number buttons to enter your current 4-digit pin number.

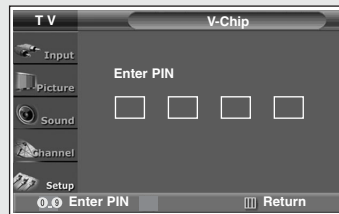

**3**

The “V-Chip” menu is displayed.

Press the **▲** or **▼** button to select “Canadian French”, then press the **ENTER** button.

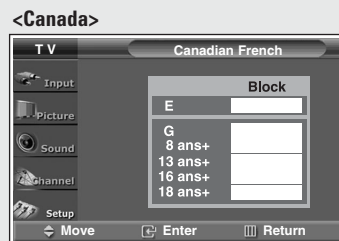

**4**

Press the **▲** or **▼** button to select the appropriate restriction, then press the **►** or **ENTER** button.

Press the **EXIT** button to exit.

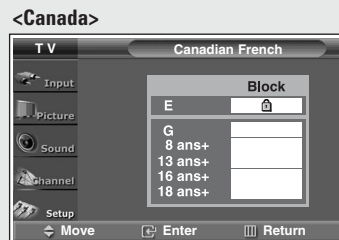

- E** Exempt programming includes...news, sports, documentaries and other information programming, talk shows, music videos, and variety programming.
- G** General.
- 8 ans+** 8+ General-Not recommended for young children.
- 13 ans+** Programming may not be suitable for children under the age of 13.
- 16 ans+** Programming is not suitable for children under the age of 16.
- 18 ans+** Programming restricted to adults.

## Customizing Your Remote Control

Your TV comes equipped with a universal remote control. In addition to controlling the TV, the universal remote control can also operate a VCR, Cable box, DVD and Set-Top Box made by Samsung (even if your VCR, Cable box and DVD are made by manufacturers other than Samsung).

- The remote control might not be compatible with all VCRs, DVD players and Cable boxes.

### Setting Up Your Remote Control to Operate Your VCR (Cable box or DVD player)

**1**

Turn off your VCR (Cable box or DVD player).

**2**

Press the **MODE** button to switch the remote control to the **VCR (CABLE or DVD)** mode.

◀ The remote control has five modes: **TV**, **STB**, **VCR**, **CABLE** and **DVD**.

**3**

On your Samsung remote control, press the **SET** button.

**4**

Enter 3 digits of the VCR (Cable box or DVD player) code listed on next page for your brand of VCR (Cable box or DVD player).

◀ Make sure you enter 3 digits of the code, even if the first digit is a "0". (If more than one code listed, try the first one.)

**5**

Press the **POWER** button on the remote control. Your VCR (Cable box or DVD player) should turn on. If your VCR (Cable box or DVD player) turns on, your remote control is now set correctly.

◀ If your VCR (Cable box or DVD player) does not turn on, repeat steps 2, 3, and 4, but try one of the other codes listed for the brand of your particular VCR (Cable box or DVD player).

**6**

Once your remote control is set up, press the **MODE** button any time you want to use the remote to operate your VCR (Cable box or DVD player).

- When your remote is in the **TV** mode, the VCR (or DVD player) control buttons (**REW**, **STOP**, **PLAY/PAUSE** and **FF**) will still operate your VCR (or DVD player).
- When your remote control is in the **STB**, **VCR**, **CABLE** or **DVD** mode, the volume buttons still control your TV's volume.

# SPECIAL FEATURES

## Remote Control Codes

### VCR Codes

Admiral	015,088	Hitachi	014,024,044,045	Quasar	017,053
Aiwa	024	Instant Replay	017	Radio Shack	011,015,017,018,021,024,028,036,052,062
Akai	026,031,032	JC Penny	011,014,016,017,023,025,039,044,060,062	RCA	009,014,016,017,037,044,046,063,078
Audio Dynamics	022,025	JCL	011,017,023,025,039,055	Realistic	011,015,017,018,021,024,028,036,052,062
Bell & Howell	011	Kenwood	011,023,025,039,055	Samsung	000,016,022,031,041,051
Broksonic	019	KLH	082	Sansui	025
Candle	016,018,022,054,055,061	LG(Goldstar)	001,002,007,018,023,055,069	Sanyo	011,021
Canon	017,062	Lloyd	024	Scott	022,050,058,077
Citizen	016,018,022,054,055,061	Logik	040	Sears	011,014,018,021,027,028,044,052,057
Colorlyme	023	LXI	024	Sharp	015,036,048,054
Craig	016,021	Magnavox	017,038,062,065	Shintom	026,035,040,064
Curtis Mathes	009,016,017,023,024,055,062,073,076	Marantz	011,017,023,025,038,039,055,070	Signature	024
Daewoo	003,004,005,006,007,008,022,054,085	MTC	016,024	Sony	026,035,047
DB	023,025	Multitech	016,024,040,041	Sylvania	017,024,038,062,065
Dimensia	009	NEC	011,023,025,039,055,070,073	Symphonic	024
Dynatech	024	Optimus	015	Tandy	011,024
Electrohome	036	Panasonic	017,062,084,086	Tatung	039
Emerson	017,018,019,022,024,029,032,036,043,050,051,056,058,066,071,074,076,077,079	Pentax	014,044	Teac	024,039,078
Fisher	011,021,027,028,052,057,067	Pentax Research+	055	Technics	017
Funai	024	Philco	017,038,062,065	Teknika	017,018,024,030
General Electric	009,016,017,041,062	Philips	017,038	TMK	076
Go Video	016	Pioneer	014,025,042,059	Toshiba	014,022,028,057,058
Harman Kardon	023	Portland	053,054,061	Toshiko	018
		PROSCAN	009	Totevision	016,018
		Quartz	011		

### Cable Box Codes

Anvision	015,016	Magnavox	015,016,027,029,034,036,037,040,041,048,049	Signature	054
Cable Star	015,016	Nawoo	001	Sprucer	035
DaeHan	005	NSC	017	Starcom	054
DeaRyung	003	Oak	024,046	Stargate2000	066
DongKuk	004	Osk Sigma	024	Sylvania	019,067
Eagle	015,016	Panasonic	011,035,047,069	TaePyungYang	002
Eastern International	020	Philips	015,016,027,029,034,036,037,040,041,048,049	Texscan	019,067
General Instrument	054	Pioneer	026,028,052	Tocom	025,029,057,058,063
GI	012,013,023,031,032,033,038,044,075,076,077	Randtek	015,016	Unika	039,040,049
Hamlin	011,012,020,021,042,056	RCA	008,035,074	Universal	059,060
Hitachi	045,051,054	Regal	011,020,021	Viewstar	015,016,027,029,034,036,037,040,041,048,049
Jerrold	012,013,023,031,032,033,038,044,054,070,073	Regency	010,041	Warner Amex	052
LG(Goldstar)	006	Saewoo	007	Zenith	022,050,065,069
Macom	045,051	Samsung	000,011,030,052,071,072		

### DVD Codes

Curtis Mathes	009	Philips	007	Sharp	005
JVC	003	PROSCAN	008	Sony	004
LG(Goldstar)	001	RCA	008	Toshiba	002
Panasonic	006	Samsung	000		

# Chapter Five

## TROUBLESHOOTING

If the TV seems to have a problem, first try this list of possible problems and solutions. If none of these troubleshooting tips apply, then call your nearest service center.

### Identifying Problems

Problem	Possible Solution
Poor picture.	Try another channel. Adjust the antenna. Check all wire connections.
Poor sound quality.	Try another channel. Adjust the antenna. Make sure the <b>MUTE</b> button is off.
No picture or sound.	Try another channel. Press the <b>SOURCE</b> button. Make sure the TV is plugged in. Check the antenna connections.
No color, wrong colors or tints.	Make sure the program is broadcast in color. Adjust the picture settings.
Picture rolls vertically.	Adjust the antenna. Check all wire connections. If you are using a VCR, check the tracking.
The TV operates erratically.	Unplug the TV for 30 seconds, then try operating it again.
Your remote control does not operate your TV.	Press the <b>MODE</b> button to put your remote control in the <b>TV</b> mode. Make sure the remote has batteries.
The TV won't turn on.	Make sure the wall outlet is working. Make sure the remote has batteries.

## Cleaning and Maintaining Your TV

With proper care, your TV unit will give you many years of service. Please follow these guidelines to get the maximum performance from your TV.

### Placement

- Do not place the TV near extremely hot, cold, humid or dusty places.
- Do not place the TV near appliances with electric motors that create magnetic fields, such as vacuum cleaners.
- Keep the ventilation openings clear; do not place the TV on a soft surface, such as cloth or paper.
- Place the TV in a vertical position only.

### Liquids

- Do not handle liquids near or on the TV. Liquids that spill into it can cause serious damage.

### Cabinet

- Never open the cabinet or touch the parts inside.
- Wipe your TV with a clean, dry cloth. Never use water, cleaning fluids, wax, or chemicals.
- Do not put heavy objects on top of the cabinet.

### Temperature

- If your TV is suddenly moved from a cold to a warm place, unplug the power cord, and allow at least two hours for moisture that may have formed inside the unit to dry completely.

## Using Your TV in Another Country

If you plan to take your TV with you to a foreign country, please be aware of the different television systems that are in use around the world. A TV designed for one system may not work properly with another system due to differences in the TV channel frequencies.

## Specifications

Model	HC-P4252W	HC-P4752W	HC-P5252W
Voltage	AC 120V	AC 120V	AC 120V
Frequency of Operation	60Hz	60Hz	60Hz
Power Consumption	240 watts	240 watts	240 watts
Dimension (W x D x H)	1004 x 471 x 967 mm 39.5 x 18.5 x 38.1 inches	1127 x 620 x 984 mm 44.4 x 24.4 x 38.7 inches	1226 x 570 x 1276 mm 48.3 x 22.5 x 50.2 inches
Weight	40.4 Kg / 89.1 lbs	49.7 Kg / 109.6 lbs	59.8 Kg / 131.9 lbs

MEMO

MEMO